



WYATT MACHINE TOOLS

Equipment Catalogue



INSIDE:
RUPES | BIGFOOT
WIRBEL | STEINEL
LEISTER | PNEUTREND
DECA | OMCN
CAR-O-LINER

Shop Online www.wyatt.co.nz

388 Church St, Penrose, Auckland

Ph: 09 525 1000



Phone: +64 9 525 1000

Fax: +64 9 525 1009

Email: info@wyatt.co.nz

Web: www.wyatt.co.nz

PO Box 12421

Penrose, Auckland NZ

Showroom: 388 Church Street, Penrose, Auckland

Opening Hours: Monday - Friday, 8:30am - 4:00pm



LEADING DISTRIBUTORS OF QUALITY BRANDS

Over 40 years' experience supplying to trade professionals in the Collision Repair, Marine, Painting and Decorating and Manufacturing Industries.

CAR-O-LINER®



smirdex



PROFILE

WELCOME



Wyatt Machine Tools is proudly a NZ owned and family operated business. For over 40 years Wyatt Machine Tools has imported and distributed power tools, collision repair equipment and surface finishing products to trade professionals throughout New Zealand.

We know that wasted time means wasted money, and that maximising productivity is crucial to maintaining your profits, especially when times are tough. With this in mind, our customers can rest assured we are committed to selling only top performing and competitively priced equipment and consumable products.

We are proud to represent a range of leading brands including; RUPES, Car-O-Liner, Farecla, Pro Form, Smirdex, OMCN, Pneutrend, Eco Touch and many more... These brands represent our commitment to delivering high performance, high precision and high quality products to our customers at affordable prices. We constantly check prices to make sure we are competitive with our range of products.

We pride ourselves on our core value of maintaining exceptional customer service levels, with full product technical back-up on all items supplied and fast delivery throughout New Zealand. Our experienced sales force is available to call on customers in and around Auckland as well as providing assistance at our Penrose showroom.

All equipment is backed up by our qualified after sales service department which is dedicated to the maintenance and repair of our range. Our website has been a real success story, offering customers 24hr ordering facilities, simply visit www.wyatt.co.nz.

Paul Wyatt

Manager / Owner





CONTENTS

01	RUPES ELECTRIC TOOLS
06	RUPES BIGFOOT POLISHING
11	RUPES ELECTRIC TOOLS CONT.
13	RUPES DUST EXTRACTION
16	RUPES PNEUMATIC TOOLS
19	WIRBEL WET & DRY VACUUMS
21	WIRBEL CARPET & UPHOLSTERY
22	PNEUTREND AIR TOOLS
26	SPRAY EQUIPMENT
27	AIR / PNEUMATIC FITTINGS
28	SPRAY GUN WASHERS
29	SAFETY EQUIPMENT
30	PROFESSIONAL HEAT TOOLS
32	INFRARED EQUIPMENT
33	STANDS & STORAGE SOLUTIONS
36	MASKING MACHINES
36	ROLL CAGES, RACKS & STANDS
37	HAND TOOLS
39	BODY REPAIR EQUIPMENT
41	CHAINS, HOOKS & CLAMPS
44	WELDING EQUIPMENT
46	CAR-O-LINER

WYATT MACHINE TOOLS



24/7
ONLINE ORDERING
NOW AVAILABLE!
wyatt.co.nz

GET IN TOUCH:

Phone: +64 9 525 1000

Fax: +64 9 525 1009

Email: info@wyatt.co.nz

Web: www.wyatt.co.nz

Postal Address:

PO Box 12421

Penrose

Auckland

New Zealand

Showroom:

388 Church Street, Penrose, Auckland

Opening Hours:

Monday - Friday, 8:00am - 4:30pm



OUR TRUSTED BRAND PARTNERS



High performance, reliability and unique design: a true "Made in Italy" know how.

RUPES has been a leader in the manufacturing of innovative power tools since 1947. RUPES is an Italian company that strongly believes that innovation and quality come above all else. Their tools are precision engineered and are an investment, which ultimately saves you time, materials and protects your health. RUPES use high quality materials with exacting tolerances to make their tools the best. RUPES employs a state-of-the-art research and development centre where all tools are computer designed and tailored to each respective market's demands. Their team of engineers have a passion for their work and therefore use the best components.



Car-O-Liner's devoted team of engineers design the future of collision repair systems.

Time and time again Car-O-Liner has made important landmarks. They were the first to introduce a universal repair bench with a mechanical measuring system in 1973, and the first to introduce a computerized electronic measuring system.

To meet customers' increasing demand for one-stop shopping they have expanded their product range to include a wide selection of collision repair products.

Car-O-Liner's collision repair equipment is the best made, the easiest to learn, the simplest to use, the best backed and the most productive - and productivity means profits. With Car-O-Liner equipment in your shop, your customers - the vehicle owners and insurance companies - will experience complete satisfaction from your work.



World-class surface finishing solutions

Farecla have been supplying the Automotive Refinish Trade, Marine and Industrial sectors for over 50 years and today lead the market by offering world-class surface finishing solutions with the aim of providing exceptional results. This is achieved by increasing productivity, improving turnover and providing the complete solution for all customers.

Farecla specialise in products that produce the best results, keep the process simple and save time and money. Results from Farecla's extensive research & development programme have proven that using the correct combination of compound and applicator is critical to achieving the best results.

Each Farecla compound is developed alongside the specific Farecla applicator to provide an integrated system based on leading edge technology. Farecla offer a wide range of general use and specialist rectification compounds, each developed to meet a specific need. The Farecla range also covers compounds for dark colours & hologram removal as well as glazes for a showroom finish.





RUPES ELECTRIC TOOLS

Orbital Palm Sanders

RULE71T RUPES Electric Orbital Palm Sander with Built-in Dust Bag

Highly versatile, easy to use sanders ideal for professional applications. Lightweight, compact design can be operated with only one hand. With completely revised mechanics and an enhanced cold motor system that increases stability and durability, it reduces vibrations during usage. Supplied with a built-in dust extraction bag or can be connected to an external RUPES dust extraction system.

LE71T	
Ø Orbit mm	2
Pad Size mm	80x130
Power W	200
R.P.M	13000
Weight kg	1.15
Velcro pad	✓
Built-in dust bag	✓



Recommended Pads

Code	Ø mm	Interface	Holes
986.012	80x130	Velcro	8+4



RUER153TE / RUER155TE RUPES Electric Random Orbital Palm Sanders with Built-in Dust Bag

These new generation of RUPES ER Series palm sanders are extremely lightweight and compact, and allow for easy sanding operations with one or two hands in confined working areas. These variable speed random orbital sanders are ideal for all types of surfaces from roughing to finishing. The interchangeable 150mm and 125mm back up pads make these the most versatile random orbital sanders available (125mm pads sold separately). The new RUPES multihole slim pad, with reduced height, allows you to reach small and tiny areas, while also increasing stability. Available in 3mm Diameter orbit for finishing, or 5mm diameter orbit for the preparation of surfaces. Featuring the new paper ECOFILTER dust collection bag and a swivel attachment to connect sander to an external RUPES dust extraction system.



	ER153TE	ER155TE
Ø Orbit mm	3	5
Pad size mm	125 or 150	125 or 150
Holes Pad	8+8+1/Multihole	8+8+1/Multihole
Power W	310	310
R.P.M	4000-10000	4000-10000
Weight kg	1.5	1.5
Speed control	✓	✓
Pad thread	M8	M8
Built-in dust bag	✓	✓



Recommended Pads

Code	Ø mm	Interface	Hardness	Fitting	Holes
980.015	125	Velcro	Hard	M8	8+8+1 Slim
981.320	150	Velcro	Hard	M8	Multihole Slim
981.330	150	Velcro	Soft	M8	Multihole Slim
981.340	150	Velcro	Hard	M8	Multihole



RULS71T / RULS71TE

RUPES Electric Orbital Delta Palm Sanders with Built-in Dust Bag

The light alloy delta base plate has been specifically designed for sanding in difficult to access areas. The lightweight, compact design can be operated with only one hand. Supplied with a built-in dust extraction bag or can be connected to an external RUPES dust extraction system.



	LS71T	LS71TE
Ø Orbit mm	2	2
Pad size mm	Delta	Delta
Power W	200	200
R.P.M	13000	8000-13000
Weight kg	1.15	1.15
Velcro Pad	✓	✓
Speed Control		✓
Built-in dust bag	✓	✓

Recommended Pads



Code	Ø mm	Interface	Holes
985.006	Delta	Velcro	Multihole



Random Orbital Sanders

RURX153A / RURX156A

RUPES 'Skorpio E' 150mm Electric Random Orbital Palm Sanders with Advanced Brushless Motor

The new SKORPIO E represents the first RUPES random orbital electric sander using **advanced brushless motor** technology. The high efficiency brushless motor guarantees power and performance for virtually any application, maintaining the speed even under heavy load conditions.

The Skorpio E features optimized ergonomics which make it comfortable and easy to use, while the innovative design provides incredible maneuverability and balance to guarantee precise and efficient sanding results. SKORPIO E is also quiet, extremely lightweight, and with a low vibration level maximizing operator comfort.

	RX153A	RX156A
Ø Orbit mm	3	6
Pad size mm	150	150
Holes Pad	Multihole	Multihole
Power W	250	250
R.P.M	4000-10000	4000-10000
Weight kg	1.2	1.2
Speed control	✓	✓
Pad thread	5/16"	5/16"



Recommended Pads

Code	Ø mm	Interface	Hardness	Fitting	Holes
981.500	150	Velcro	Hard	M8	Multihole Slim
981.600	150	Velcro	Hard	5/16"	Multihole Slim



RUER03TE / RUER05TE
RUPES Electric Random Orbital Sanders with Built-in Dust Bag

These models are part of the new generation of RUPES sanders. Power, ergonomics and excellent balance are the key features of this sander, making it particularly suitable for heavy-duty use. The electronic module enables the operator to adjust speed, achieve maximum power, and maintain a consistent torque - even at low speeds. Equipped with an anti-spinning system to reduce the undesired rotation of the pad to protect the surface from scratches. Fitted with 6+8+1 velcro pad which enables the use of all types of paper (6+1, 8+1, 15 holes). Supplied with a built-in dust extraction bag, or can be connected to an external RUPES dust extraction system. Available in two versions; 3mm diameter orbit for finishing, or 5mm diameter orbit for the preparation of surfaces.

	ER03TE	ER05TE
Ø Orbit mm	3	5
Pad size mm	150	150
Power W	450	450
R.P.M	5000-10000	5000-10000
Weight kg	2.1	2.1
Speed Control	√	√
Pad Thread	M8	M8
Built-in dust bag	√	√



Recommended Pads

Code	Ø mm	Interface	Hardness	Fitting	Holes
981.320	150	Velcro	Hard	M8	Multihole Slim
981.330	150	Velcro	Soft	M8	Multihole Slim



RUBR106AES / RUBR109AES / RUBR112AES
RUPES Electric Random Orbital Sanders

New release made. 20% more power compared to a traditional 5mm orbit. Ultra-high torque sanders for high removal capacity. Ideal for heavy duty applications where power and flexibility of the tools is required. The random orbital movement combined with ample torque make this an easy tool to use while offering excellent performance. Supplied with Multihole Slim Pad, with reduced thickness, for increased stability. Equipped with an anti-spinning system to reduce the undesired rotation of the pad and protect the surface from scratches. Connects to an external RUPES dust extraction system; the connection sleeve includes an air flow regulation valve for controlling the suction effect.

	BR106AES	BR109AES	BR112AES
Ø Orbit mm	6	9	12
Pad size mm	150	150	150
Holes Pad	Multihole Slim	Multihole Slim	Multihole Slim
Power W	550	550	550
R.P.M	3000-7000	3000-7000	3000-7000
Weight kg	2.2	2.2	2.2
Speed Control	√	√	√
Pad Thread	M8	M8	M8



Recommended Pads

Code	Ø mm	Interface	Holes	Hardness	Fitting
981.320	150	Velcro	Multihole Slim	Hard	M8
981.330	150	Velcro	Multihole Slim	Soft	M8
981.340	150	Velcro	Multihole	Hard	M8



(Older Models pictured)





RUSSCA
RUPES Electric Orbital Sander

High performance sander designed for quickly removing materials from a vast range of surfaces. The additional handle enables operators to work comfortably and safely. Features include excellent balance, advanced gear transmission, a protective dust filter for the motor. Their ability to perform under heavy duty working conditions, the minimal vibrations and superior control of the machine ensure high quality sanding results. Supplied with a built-in dust extraction bag or can be connected to an external dust RUPES dust extraction system.



SSCA	
Ø Orbit mm	5
Pad size mm	115x210
Power W	350
R.P.M	6000
Weight kg	3.6
Paper Clips	✓
Built-in dust bag	✓

Recommended Pads

Code	Ø mm	Interface	Holes
62.55	115x205	Velcro	10 Hole
983.002	115x205	Rubber	10 Hole
983.001	115x205	Rubber	No Hole



RUSSPF
RUPES Electric Orbital Sander

High performance sander designed for quickly removing materials from a vast range of surfaces. The additional handle enables operators to work comfortably and safely. Features include excellent balance, advanced gear transmission, a protective dust filter for the motor. Their ability to perform under heavy duty working conditions, the minimal vibrations and superior control of the machine ensure high quality sanding results. This sander can be connected to an external dust extraction system.



SSPF	
Ø Orbit mm	5
Pad size mm	115x210
Power W	350
R.P.M	6000
Weight kg	3.6
Paper Clips	✓

Recommended Pads

Code	Ø mm	Interface	Holes
62.55	115x205	Velcro	10 Hole
983.002	115x205	Rubber	10 Hole
983.001	115x205	Rubber	No Hole



RUSL42A
RUPES Electric Long Board Orbital Sander

The power, the diameter of the orbit and the shape of the baseplate enables fast removal of material, a good surface finish and excellent "flattening off" on large, flat surfaces. This sander can be connected to an external RUPES dust extraction system.



RUSL42A	
Ø Orbit mm	4.8
Pad size mm	70x400
Power W	550
R.P.M	3000-7000
Weight kg	2.6
Speed Control	✓
Velcro Pad	✓

Recommended Pads

Code	Ø mm	Interface	Holes
619.153	70x400	Velcro	14



Planetary Sanders

**RUEK150AES / RUEK200AS
RUPES Electric Gear Driven Planetary Sanders**

High performance sanders for heavy duty operation. The planetary movement maximizes removal power, whilst minimizing machining time. The ideal solution for roughing and preparing surfaces quickly without spreading dust, overheating or excessive surface aggression. These sanders connect to an external RUPES dust extraction system; the connection sleeve includes an air flow regulation valve for controlling the suction effect.

	EK150AES	EK200AS
Ø Orbit mm	5	5
Pad size mm	150	200
Power W	550	550
R.P.M	200-500	500
Stroke p/min	2800-7000	7000
Weight kg	2.7	3.1
Speed Control	✓	
Velcro Pad	✓	✓
Holes	6+1	8
Side Handle	✓	✓



Recommended Pads

Code	Ø mm	Interface	Holes
981.100	150	Velcro	6+1
912.279	200	Velcro	8



Dual Purpose Polisher / Sanders

**RULH32E / RULH232
RUPES Electric Polisher / Sanders**

Dual purpose RUPES power tool capable of performing both sanding and finishing operations on a wide range of materials. Features include; balanced body, low noise, and provision for sanding pads and polishing pads.

RULH32E is equipped with multifunction electronics; soft start-up device for spreading the polishing pastes without wasting the product, speed regulation with torque control and a safety device in case of an overload. The protected side handle provides a more safe/secure grip when operating the machine.

RULH232 features include balanced body, low noise, and provision for sanding pads (178mm max) and polishing pads (up to 200mm). The protected side handle provides safe grip when operating the machine.

	LH32E	LH232
Ø Disc pad max mm	178	178
Power W	1200	1200
R.P.M	1400-3400	1600-3400
Weight kg	3.3	3.7
Speed control	✓	
Spindle Thread	M14	M14
Shaft locking button	✓	
Side handle	✓	✓



RUPES BIGFOOT POLISHING REVOLUTION

Achieving polished perfection on a surface as efficiently as possible is the primary goal of the BigFoot project. BigFoot simplifies the polishing process, substantially reducing polishing time and producing the optimum result. Thanks to the complete range of polishers, pads and compounds, all designed to work in synergy, BigFoot's innovative system based approach guarantees exceptional results in less time for virtually any polishing application.



TYPES OF MOVEMENT

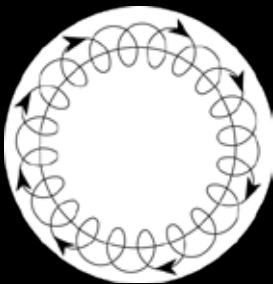

Random Orbital

Random orbital polishers are a combination of rotary and standard orbital polishers.

The speed of a random orbital polisher is counted in orbits per minute (OPM).

Unlike a rotary polisher, which is forced to spin, a random orbital polisher actually rotates from the momentum created by the high speed orbital motion. The pattern is truly random, as the combination of stroke length, pad size, pad grip, and speed can alter the pattern of motion.

Pros

- The random orbital movement is at present the best compromise in terms of effectiveness and surface treatment quality.
- Great for learning - This machine very safe and easy to use for beginners.

Cons

- Cut not as strong as a rotary



Rotary

Rotary polishers spin the pad in a circular motion on a central axis, with the highest velocity being at the pads edge.

Rotary tends to be the most invasive type of movement on the surface. This consistent circular motion generates substantial cut (friction).

Pros

- Unparalleled cut and capability
- Stronger than any other type of machine

Cons

- Most invasive on paint surface - Generating friction and heat which can lead to burns, and damage a vehicles finish, causing strike throughs and rotary induced swirl marks if used improperly.
- Difficult to master (not recommended for beginners) - In the hands of a skilled technician a rotary tool features the lowest vibration levels of any tool movement, but can take a great deal of time to learn to use the tool properly.
- Multi-step polishing - to remove swirls



Gear Driven

A gear driven polisher combines both the rotary and orbital motions into one forced action. The difference between this and a random orbital polisher is that a forced rotation drives both orbit and rotation motions, compared with a random orbital movement which only drives orbit and relies on momentum to rotate the pad. This means that a forced rotation gear driven polisher has a consistent pattern. They are as easy to use as a random orbit but slightly more aggressive on surfaces than a random orbital movement and generates a generally higher vibration level.

Pros

- Stronger than a random orbit polisher, yet safe for beginners

Cons

- Fixed rotation can limit it's polishing capabilities

RUPES BIGFOOT POLISHING KITS

BigFoot Mark II Kits

The next generation of RUPES is here – the RUPES BigFoot Mark II Polishers.

Built with everything that made the original RUPES BigFoot Polishers legendary in the detailing community, the new RUPES Mark II series will blow you away. The RUPES Mark II Polishers have taken on the successful elements of the original 'BigFoot' machine and improved upon them. This new version offers a larger motor, improving efficiency by up to 30% over the original model. The result is shorter working times and more uniform polishing results even on contoured surfaces. Busy professional detailers will be impressed with the speed with which a high gloss, swirl-free result is achieved! Improved ergonomics and robust design complete the package!



No Holograms



Easy to Use



Faster Machining Operations



Superior Finish

RULHR21M2K

RUPES BigFoot Mark II 21mm Random Orbital Polisher Deluxe Kit

The RUPES LHR21II BigFoot Mark II Random Orbital Polisher gets its name from its massive, industry leading 21mm orbit. The advantage of a larger throw is that more surface area is being covered as you polish. The polisher ensures a perfect finish with its random orbital motion. Simply put, the RUPES LHR 21II BigFoot Mark II Random Orbital Polisher leaves you with a perfect finish that's free of swirls and holograms – all without the risk of burning through the paint. It is so easy to use that even a novice can have the polisher mastered after only one panel! Its 6 inch hook and loop backing plate is the perfect size for polishing horizontal and other large body panels.

The RUPES BigFoot Mark II Random Orbital Polisher Deluxe Kit is an all-inclusive kit that contains everything you need to remove swirls, scratches, water spots and anything else that hinders the shine of your vehicle's paint! The kit includes the legendary LHR 21II BigFoot Random Orbital Polisher along with the complete BigFoot Polishing System that showcases RUPES foam pads and polishing compounds. It also includes a host of other essential polishing accessories including the Polisher Bag and everything else you need to get started.

LHR 21II Deluxe Kit includes:

- RUPES BigFoot Mark II 21mm Electric Random Orbital Polisher LHR21II
- RUPES BigFoot Polisher Bag
- RUPES BigFoot Detailing Apron
- RUPES Zephir Gloss Coarse Gel Compound 250ml
- RUPES Quarz Gloss Medium Gel Compound 250ml
- RUPES Keramik Gloss Fine Gel Polish 250ml
- RUPES Diamond Ultra Fine Gel Polish 250ml
- Blue Coarse Foam Pad, 180mm
- Green Medium Foam Pad, 180mm
- Yellow Polishing Foam Pad, 180mm
- White Finishing Foam Pad, 180mm
- Microfibre detailing cloths x 4

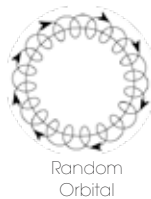

LHR 21II	
Ø Orbit mm	21
Backing Pad mm	150
Polishing Pad mm	180
Power W	500
R.P.M	2500-4700
Weight kg	2.25
Speed regulation	✓
Fitting	M8



Recommended Backing Pad

Code	Ø mm	Interface	Polishing Pad	Fitting
981.321	150	Velcro	Foam	M8

RULHR15M2K

RUPES BigFoot Mark II 15mm Random Orbital Polisher Deluxe Kit

The RUPES LHR 15II BigFoot Mark II Random Orbital Polisher has the same innovative design as the LHR 21II, yet the 15mm orbit combined with the 125mm backing pad allows the machine to fit into tighter spaces, making it perfect for working in contoured areas and narrow surfaces.

The 15mm orbit coupled with the higher R.P.M. level than that of the LHR 21II gives this polisher the equivalent cutting power to the LHR 21II. Its 130/150mm BigFoot polishing foam pads, perfect balance and vibration-free operation make the LHR 15II a versatile favourite of detailers everywhere.

The polisher ensures a perfect finish with its random orbital motion and large throw. One of the biggest advantages of the LHR 15II is that no swirls or holograms are instilled into the paint as you polish – all without the risk of burning through the paint. The RUPES LHR 15II is so easy to use that even a novice can have the polisher mastered after only one panel!

LHR 15II Deluxe Kit includes:

- RUPES BigFoot Mark II 15mm Electric Random Orbital Polisher LHR15II
- RUPES BigFoot Polisher Bag
- RUPES BigFoot Detailing Apron
- RUPES Zephir Gloss Coarse Gel Compound 250ml
- RUPES Quarz Gloss Medium Gel Compound 250ml
- RUPES Keramik Gloss Fine Gel Polish 250ml
- RUPES Diamond Ultra Fine Gel Polish 250ml
- Blue Coarse Foam Pad, 150mm
- Green Medium Foam Pad, 150mm
- Yellow Polishing Foam Pad, 150mm
- White Finishing Foam Pad, 150mm
- Microfibre detailing cloths x 4

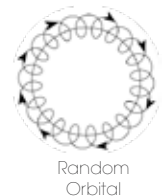

LHR 15II	
Ø Orbit mm	15
Backing Pad mm	125
Polishing Pad mm	150
Power W	500
R.P.M	2500-5300
Weight kg	2.20
Speed regulation	✓
Fitting	M8



Recommended Backing Pad

Code	Ø mm	Interface	Polishing Pad	Fitting
980.027	125	Velcro	Foam	M8

RUPES BIGFOOT POLISHING KITS

RULHR75E - MINI

RUPES BigFoot LHR 75E Mini Random Orbital Polisher Deluxe Kit

Polish small and intricate body panels with precision!

The RUPES LHR 75E Mini BigFoot Random Orbital Polisher is a must for any detailer wishing to obtain perfect results, it makes it possible to polish every square inch of your vehicle, especially difficult shapes, and for spot repair operations. The 12mm orbit, combined with RUPES accessories and consumables, achieves quick results on areas such as mudguards, front panels etc.

The RUPES LHR 75E Mini Random Orbital Polisher features a compact, lightweight body that is designed to be used with polishing pads ranging from 3 to 4 inches.

The Deluxe Kit includes the polisher plus a handful of RUPES foam pads, RUPES polishing compounds, and a host of other essential accessories for making for your vehicle's finish flawless. Best of all, the RUPES LHR 75E Mini BigFoot Random Orbital Polisher Deluxe Kit includes a RUPES bag to carry everything around in.

LHR75E-MINI Deluxe Kit includes:

- RUPES BigFoot Mini Electric Random Orbital Polisher LHR75E Mini
- RUPES BigFoot Polisher Bag
- RUPES BigFoot Detailing Apron
- RUPES Zephir Gloss Coarse Gel Compound 250ml
- RUPES Keramik Gloss Fine Gel Polish 250ml
- Blue Coarse Foam Pad, 80mm/100mm x 2
- Yellow Polishing Foam Pad, 80mm/100mm x 2
- Microfibre detailing cloths x 4

RUPES BigFoot LHR 75E Mini Random Orbital Polisher is also sold individually RULHR75EP

LHR 75E	
Ø Orbit mm	12
Backing Pad size mm	75
Power W	400
R.P.M	4000-5500
Weight kg	2.3
Speed regulation	✓
Backing Pad Thread	M6



Recommended Backing Pad

Code	Ø mm	Interface	Fitting
990.007	75	Velcro	M6



RULH19EKIT

RUPES BigFoot LH 19E Professional Rotary Polisher Standard Kit

Here Now!

Featuring a high torque 1200 watt motor, compact design, premium ergonomics and a lightweight housing, the LH 19E is one of the most capable and manoeuvrable rotary polishers on the market. Its' lightweight and powerful design makes it the ultimate rotary polishing solution for a variety of industries including automotive detailing, collision repair and refinishing, marine, and more.

Unlike all other RUPES BigFoot polishers, this machine only has a rotary drive. This allows you to polish faster, harder, deeper and more aggressively.

Thanks to the powerful engine and high torque, you get a great result in a short period of time. Rotary machines typically have faster speed settings when compared with dual action polishers.

The heavy duty extra long 9m cord is gauged to deliver maximum power to the polisher for safe, efficient operation. An innovative soft grip loop handle allows users to hold the polisher securely at different angles for precision and stability during the polishing process. The LH19E includes a progressive trigger which acts as a throttle allowing the operator to control speeds within the dial range to deliver the exact speed and to adjust quickly.

LH 19E Standard Kit includes

- RUPES BigFoot LH 19E Professional Rotary Polisher
- RUPES BigFoot Rotary Polishing Compound Coarse 250ml
- RUPES BigFoot Rotary Polishing Compound Fine 250ml
- Polishing backing pad Ø 125mm
- Rotary Polishing Foam Pad Coarse
- Rotary Polishing Foam Pad Fine
- Anti-vibrating soft grip loop handle

RUPES BigFoot LH 19E is also sold individually RULH19E

LH 19E	
Backing Pad size mm	125/150/165
Power W	1200
R.P.M	450-1700
Weight kg	2.2
Speed regulation	✓
Backing Pad Thread	M14



Recommended Backing Pads

Code	Ø mm	Interface	Fitting
982.500	125	Velcro	5/8"
982.600	150	Velcro	5/8"
982.650	165	Velcro	5/8"
992.500	125	Velcro	M14
992.600	150	Velcro	M14
992.650	165	Velcro	M14

5/8" Thread



M14 Thread

RULK900EDLX
RUPES BigFoot Mille LK 900E Gear Driven Dual Action Polisher Deluxe Kit

The New BigFoot Mille Gear Drive Polisher Offers Faster Cutting Over Curved Surfaces

Bridging the gap between rotary and free spinning orbital polishers, the BigFoot Mille delivers powerful defect removal, versatility, and consistent performance in an ergonomic package, designed with operator comfort and efficiency of work in mind. Featuring a wide assortment of new, innovative features, as well as a revolutionary clockwise rotational movement.

The RUPES BigFoot LK900E 'Mille' was designed with the aim of providing a forced rotation machine that offered faster cutting capability than other gear driven models on the market, and also faster cutting than the BigFoot LHR21 MK II or the BigFoot LHR15 MK II. As a result, the Mille provides exceptional cutting power with minimal heat generation and very little steering, more in line with a standard DA.

The RUPES Bigfoot Mille LK 900E allows the use of two different pad diametres, 125mm and 150mm, making the new polisher incredibly versatile for numerous polishing operations. The heavy duty extra long 9m cord is gauged to deliver maximum power to the polisher for safe, efficient operation.

LK 900E Deluxe Kit includes:

- RUPES BigFoot Mille LK 900E Gear Driven Dual Action Polisher
- RUPES BigFoot Dark Grey Polisher Bag
- RUPES BigFoot Mille Polishing Compound Coarse 250ml
- RUPES BigFoot Mille Polishing Compound Fine 250ml
- Polishing backing pad 981.089M
- Blue Coarse Wool Polishing Pad - 9BW150H
- Yellow Medium Wool Polishing Pad - 9BW150M
- Mille Polishing Foam Cutting Pad Blue Coarse - 9BG150H
- Mille Polishing Foam Finishing Pad Yellow Fine - 9BG150M
- Microfibre detailing cloths x 4
- P808 Protective Sealant 500ml
- BigFoot Claw Pad Tool

LK 900E	
Ø Orbit mm	5
Backing Pad size mm	125/150
Power W	900
R.P.M	265-535
Weight kg	2.8
Speed regulation	√
Backing Pad Thread	6 x M4

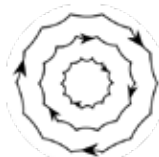

Gear Driven

RULHR12E - DLX
RUPES BigFoot 'Duetto' LHR 12E Random Orbital Sanding and Polishing Deluxe Kit

All-in-one sanding and polishing system for painted surfaces.

The RUPES LHR 12E Duetto is the result of countless hours of research and development to design what is arguably the most user-friendly dual action polisher available. The 'Duetto' continues the RUPES tradition of engineering polishers that have a larger orbit (throw) than anything else on the market. The LHR 12E Duetto, the little brother to the larger LHR 15ES and LHR21ES, features a respectable 12 mm orbit, enabling it to be used as a sander or polisher.

Designed with the professional detailer in mind, the RUPES LHR 12E Duetto is thoughtfully engineered with superb ergonomics and user-friendly switches and dials. The RUPES LHR 12E Duetto will provide hours of sanding and polishing with minimal user fatigue. The powerful 400 watt motor provides enough juice to keep the pad rotating, making it capable of removing heavy swirls, water spots, and scratches.

Dual Function: Sanding & Polishing

The RUPES LHR 12E Duetto and its 12mm orbit can be used with fine grit abrasives to speed up deep correction operations. The tool can then use foam pads and polishing compounds to refine the abrasive scratches and restore a flawless finish.

RULHR12E 'Duetto' Deluxe Kit includes:

- RUPES BigFoot 'Duetto' Electric Random Orbital Polisher LHR12E DUETTO
- RUPES BigFoot Polisher Bag
- RUPES BigFoot Detailing Apron
- RUPES Zephir Gloss Coarse Gel Compound 250ml
- RUPES Keramik Gloss Fine Gel Polish 250ml
- Blue Coarse Foam Pads, 130mm/150mm x 2
- Yellow Polishing Foam Pads, 130mm/150mm x 2
- RUPES Backing Pad 980.027
- RUPES Soft Interface Pad 980.041
- RUPES 2000 Grit Sanding Discs x 3
- RUPES 3000 Grit Sanding Discs x 3
- Microfibre detailing cloths x 4

LHR 12E	
Ø Orbit mm	12
Backing Pad mm	125
Power W	400
R.P.M	4000-5500
Weight kg	2.6
Speed regulation	√
Fitting	M8

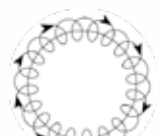

Random Orbital



Recommended Backing Pads

Code	Ø mm	Interface	Fitting
981.089	150	Velcro	M4
980.037	125	Velcro	M4



Recommended Backing Pads

Code	Ø mm	Interface	Fitting
980.027	125	Velcro	M8





**RUHR81MDLX / RUHR81MLDLX
RUPES BigFoot Nano with iBrid Dual Action Polisher Deluxe Kits**

Orbital movement, rotary movement, polishing, sanding, cleaning; all-in-one compact easy to use system.

The RUPES BigFoot Nano iBrid, is a compact and extremely light weight (470g) hand-held multi-action tool that gives you unparalleled access to hard to reach areas.

What is iBrid? Ever been burdened by the cables trailing behind and wished you had a battery pack? With iBrid technology this tool can not only be used with a corded power supply, but with a battery as well!. This dual powered machine comes with a "Plug & Play Power Supply" which allows it to act like any other corded tool, but it also comes with two Li-ION battery packs and a fast charge battery charger. 22-24 minutes is all you will need to charge the battery and each charge will run for up to 30 minutes. The two battery packs allow you to use one in the tool, while charging the other.

Multi-Action Movements & Interchangeable Accessories

This multi-action tool allows the user to switch between rotary, 3mm random orbital, and 12mm random orbital actions in just seconds. This gives you an unparalleled amount of versatility and power for any job you throw at it. Heavy imperfections, light imperfections, swirls, it really does not matter, iBrid will remove these imperfections with ease! Additionally, a variety of brushes make detail cleaning easier than ever. Like all polishing systems in the BigFoot pedigree, careful attention has been paid to the user experience. You can expect ample torque and vibration free polishing. This is an incredibly effective tool for headlights, spoilers, front bumpers, side mirrors, door handles, wheels, motorcycles and more.

Nano iBrid Deluxe Kit includes:

- RUPES BigFoot Nano iBrid Short Neck Version HR81M or Long Neck Version HR81ML
- RUPES BigFoot Premium Nano Tool Case
- Charger 9HC120LT
- AC-DC Adaptor 9HP120LT
- Rechargeable Power Pack x 2, 9HB120LT
- Rotary Functional Unit 562390
- 3mm Orbit Connector 581390/C
- 12mm Orbit Connector 58390/C
- Velcro Foam Polishing Pad Coarse Ø 34/40mm 6 PCS, 9BF40H
- Velcro Foam Polishing Pad Fine Ø 34/40mm 6 PCS, 9BF40M
- Velcro Foam Polishing Pad Coarse Ø 54/70mm 4 PCS, 9BF70H
- Velcro Foam Polishing Pad Fine Ø 54/70mm 4 PCS, 9BF70M
- Microfibre Cloths x 4
- RUPES Keramik Gloss Fine Gel Compound 150ml
- RUPES Zephir Coarse Gel Compound 150ml
- Horsehair Medium Cup Brush, 9BF3000
- Nylon Hard Cup Brush, 9BF3030
- Buffing Back Up Pad Ø 34mm, 995001
- Buffing Back Up Pad Ø 50mm, 996001
- Sanding Back Up Pad Ø 34mm, 997001
- 35mm Adhesive Discs: P2000 10 PCS + P3000 10PCS, 945520/M

**Short Neck Kit #RUHR81MDLX
Long Neck Kit #RUHR81MLDLX**

	HR81M/ML
Voltage	10.2-12
R.P.M	2000-5000
Battery Life	~30 min
Charging Time	~20 min
Speed Control	✓
Soft Start	✓
LED Status	✓
Weight g	470



Recommended Backing Pads

Code	Ø mm	
995.001	34mm	Buffing
996.001	50mm	Buffing
997.001	34mm	Sanding



RULHR75KIT / RULHR75
RUPES BigFoot Pneumatic LHR 75 Random Orbital Polishing Spot Repair Kit

Polish small panels and perform spot repairs with confidence! Thanks to its compact and ergonomic design, this lightweight tool is specifically developed for spot repair operations or for polishing hard to reach areas. This 75mm pneumatic polisher easily removes swirls and scratches on the most intricate body panels. The massive 15mm throw ensures uniform material removal so you're left with a flawless finish every time. It may be small, but the RUPES LHR75 75mm Pneumatic Random Orbital Polisher packs quite a punch!

This kit is perfect for small body panels and spot repairs and includes the following:

- RUPES Pneumatic Big Foot 75mm Mini Random Orbital Polisher LHR75
- RUPES Pneumatic Mini Orbital Sander LD30
- RUPES Big Foot Gel Compound Keramik Gloss Fine 1 Litre 9.BFKERAMIK
- RUPES Big Foot Gel Compound Diamond Glass Ultra Fine 1 Litre 9.BFDIAMOND
- 2 x 75mm Hard Polishing Pads
- 2 x 75mm Soft Polishing Pads
- Microfibe Cloth
- T Shirt

RUPES BigFoot LHR 75 Pneumatic Random Orbital Polisher is also sold Individually RULHR75



LHR 75	
Ø Orbit mm	15
Backing Pad size mm	75
Max Consumption Air L/min	320
R.P.M	0-11000
Working Pressure Bar	6
Weight kg	0.65
Speed regulation	✓
Fitting	M6



Recommended Backing Pad

Code	Ø mm	Interface	Fitting
990.007	75	Velcro	M6

RUPES ELECTRIC TOOLS CONT'D

Polishers

RUF32ES
RUPES Electric Mini Angular Polisher

A mini-polisher with ultra-light weight and dimensions, yet extremely powerful and high-performing. Features include electronic Soft Start-Up device for spreading the polishing pastes without wasting the product, and speed regulation with torque control. RUF32E is ideal for vertical polishing and retouching operations that require the use of a small tool, and the removal of enamels and glazes and for fine finishing work.

RUF32ES	
Ø Polishing pad mm	75
Power W	900
R.P.M	1500-4000
Weight kg	1.8
Speed control	✓
Spindle thread	M14
Side Handle	✓



Recommended Backing Pads

Code	Ø mm	Interface	Fitting
990.015	75	Velcro	M14





RULH22EN
Electric Angular Polisher

The latest generation of RUPES polisher developed to achieve maximum results with leading polishing brands such as Farécla. Features include: spindle locking button for quick pad replacement, protective side handle, soft start up for spreading of polishing pastes without wasting the product, and speed regulation with torque control.



RULH22EN	
Ø Polishing pad mm	200
Power W	1020
R.P.M	900-2000
Weight kg	3.3
Speed control	✓
Spindle thread	M14
Shaft locking button	✓
Side handle	✓

Recommended Backing Pads

Code	Ø mm	Interface	Fitting
992.001	122	Velcro	M14
861.097	110	Adhesive	M14



Grinders

RUBA215
RUPES Mini Angular Grinder

A powerful, high torque grinder, yet compact and easy to handle. Ideal for sharpening, grinding and cutting. Equipped with a shaft locking button for fast disc removal, and an ergonomic handle for left or right-hand side use. Because of this it's small dimensions, this model is suitable to perform machining operations directly onto bodywork, and to cut and grind metal sheet surfaces, and tiles or ceramics and granite cutting.



RUBA215	
Ø Disc mm	115
Power W	950
Revs R.P.M	11000
Weight kg	2.1
Spindle locking button	✓
Turning guard	✓
Side handle	✓
Fitting	M14



RUBA31E
RUPES Mini Angular Grinder

This mini angular grinder is able to machine at low rotation speeds ranging from 1500 to 4000 r.p.m. Particularly suited to roughing operations, for the preparation of surfaces and removal of oxides. This grinder is suitable for grinding and polishing with fibre discs.

Equipped with a shaft locking button for fast disc removal, an electronic module with speed adjustment and overload control, and an ergonomic handle for left or right-hand side use.

This grinder can be connected to an external RUPES dust extraction system.



RUBA31E	
Ø Disc mm	115
Power W	900
Revs R.P.M	1500-4000
Weight kg	1.8
Speed control	✓
Spindle locking button	✓
Turning guard	✓
Side handle	✓
Fitting	M14

RUPES DUST EXTRACTION

Single and Twin Operator Dust Extraction Units

RUSV10E

RUPES Portable Single Operator Dust Extraction Unit

Powerful and compact portable dust extraction unit for connection to a wide range of RUPES electric equipment. With its compact size, carry handle and weighing just 6.5Kg it can be easily transported.

The RUSV10E RUPES Portable Dust Extraction Unit compliments the RUPES Carrier System, being designed to sit neatly on top, ensuring both sanding & dust extraction equipment can be easily transported to the work area in one go. Complete with a power socket for tools up to 1000W, a dust bag capacity of 3.5Kg, a 5m hose and a range of cleaning attachments so it can also be used as a vacuum. An optional shoulder strap is sold separately.

	RUSV10E
Flow Capacity m ³ /h	100
Vacuum Nozzle nr.	1
Noise dB(A)	75
Capacity Bag Kg	3.5
Vacuum Level mm/H ₂ O	1600
Weight Kg	6.5
Power Max W	1x1000
Power W	1150



RUS130EL / RUS130PL / RUS145EL / RUS145EPL

RUPES 'S' Series Mobile Dust Extraction Units - Single Operator

With a 1200 watt motor these are extremely versatile and compact dust extraction units are suitable for extracting dust from grinding and various types of industrial work. Fitted for connection to an electric tool (with a maximum power of 2400 Watts), or a pneumatic tool (P versions). The operator can choose between manual or automatic start up of the extractor when the connected tool is started. Features variable suction control.

To ensure maximum extraction efficiency under all working conditions, the version 'E' extractors have an automatic filter cleaning system. By means of a system of valves, the air flow passing through the filters is inverted in alternation every 30 seconds, ensuring efficient cleaning action. With this innovative system, the operator is able to continue working without any interruption or reduction in the extraction process.

Rated 'L' Class Dust Extraction filter - with a maximum tolerated exposure value > 1.0 mg/m³ (according to the EN60335-2-69/A2 standard). Suitable for all type of work on surfaces with power tools - bodywork - wood - plastic.

Features a convenient, multi-purpose shelf for storing tools and attachments. Electrostatic charge dispersion device.

Supplied with a multi-purpose swivel extraction attachment that makes it possible to use extraction hoses with diameters of 25, 29, 38 and 50 mm, making the extractor adaptable to any application. Comes complete with a 4m hose and filter bag.

	RUS130	RUS145
Power W	1x1200	1x1200
Weight Kg	10.5	13.5
Tool Power, max W	1x2400	1x2400
Noise dB(A)	70	67
Container Volume L	30	45
Air Flow m ³ /h	165	165
Rated Dust Class	L	L
Connectable Tools	1	1
Electrical Outlet for Tools	1	1
Air Connections for Tools	P versions	P versions
Connector Attachment	50mm	50mm
Automatic filter cleaning	E versions	E versions
PNEUMATIC VERSION (P versions)		
Feed pressure Bar	6	6
Max. air flow rate l/min	1450	1450



Sander and tool holder (pictured) sold separately.

Available versions:
RUS130EL, RUS130PL, RUS145EL, RUS145EPL

RUPES DUST EXTRACTION



RUKS260E

Available versions:
RUKS260E, RUSK260ES, RUKS260EP, RUKS260EPS

RUKS260E / RUSK260ES / RUKS260EP / RUKS260EPS RUPES Mobile Dust Extraction Units - Twin Operator

With two x 1000 Watt motors, these powerful, robust and reliable RUPES Mobile Dust Extraction Units are fitted for simultaneous connection with two tools - electric or pneumatic tool (P versions). Features a dual-startup system, the operator can choose between manual or automatic start up of the extractor when the connected tool is started. Features variable suction control.

Features include pivoting wheels that brake, a hinged front hatch for easy access to the dust bag. The exhaust at the rear of the unit can be ducted outside with the use of an Evaflex hose.

Rated 'M' Class Dust Extraction filter - with a maximum tolerated exposure value > 0.1 mg/m3 (according to the EN60335-2-69/A2 standard). The unit can be used for extraction of ordinary dust and grinding products in all sectors.

The top shelf provides a useful storage solution for keeping tools and machines conveniently on hand. There are also two side holders to store the extraction hoses so the operator's work area can be kept clear at all times.

An abrasive stand fits onto the back of this unit to provide a complete integrated sanding workstation (S versions).

Comes complete with a 5m hose and filter bag.



RUKS260EPS

RUKS260	
Power W	2x1000
Weight Kg	26
Tool Power, max W	2x800, 1x1600
Noise dB(A)	72
Container Volume L	65
Flow capacity m ³ /h	260
Rated Dust Class	M
Connectable Tools	2
Electrical Outlet for Tools	2
Air Connections for Tools	P versions
Connector Attachment	50mm
Automatic filter cleaning	E versions
PNEUMATIC VERSION (P versions)	
Vacuum mm/H ₂ O	2000

Dust Bags

023.1107C / 042.1108 / 037.1101C / 001.1606 / 130.1108
RUPES Dust Bags

Recommended Bags

Code	Description	Qty/Pack	Models
130.1108	Fleece Dust Bag	Each	S130/S145
023.1107C	Paper Filter Bag	5	SV10E
042.1108	Paper Filter Bag	5	S130/S145
037.1101C	Paper Filter Bag	5	KS260
001.1606	Paper Filter Bag	5	S135 / S235 / KX135



Save Now on a Premium RUPES Dustless Sander / Vacuum Package

By combining high performance sanding and dust extraction equipment, RUPES has found the solution to virtually eliminate all sanding dust, creating a healthier, more efficient working environment. Wyatt Machine Tools have put together a range of mobile RUPES Dustless Sanding packages. Each package includes one of the premium RUPES mobile extraction units and a sander(s). Visit our website for more information. www.wyatt.co.nz

RUSP235

RUPES Air Driven Portable Vacuum

Air driven portable vacuum unit for sanding dust and valeting. Thanks to the special Venturi system it operates in any environment where there is no electric power.



RUSP235	
Working pressure Bar	6
Air quick coupling nr	1
Vacuum nozzle nr.	1
Capacity bag Kg	5
Vacuum mm/H ₂ O	1900
Flow capacity m ³ /h	100
Weight Kg	8
Max. air flow rate l/min	1000

RUKX135

RUPES Pneumatic ATEX approved Vacuum Unit on Trolley

Designed for safe working in potentially explosive atmospheres up to zone 22 (ATEX 99/92/CE). Supplied with 5m Evalflex hose Ø 29 mm, Dust bag 001_1606/C, Rotating sleeve.



RUKX135	
Working pressure Bar	7
Air quick coupling nr	1
Vacuum nozzle nr.	1
Capacity bag Kg	5
Vacuum mm/H ₂ O	1900
Flow capacity m ³ /h	100
Weight Kg	30
Max. air flow rate l/min	1000
Noise dB(A)	78
Tank Capacity L	20
Filter Surface m ²	0.5

RUKR2A

RUPES KR2A Mobile Dust Extraction Turbine 1,5 kW - 2 HP - Twin Operator

Extremely flexible vacuum unit; it's compact, simple to install and it can be easily moved around the working area! This mobile unit suitable for multiple operators offers everything that a bodyshop user needs from a workstation. Equipped with a series of innovative features, such as the new automatic filter cleaning system with powerful compressed air jets, new highly efficient pump compared to some of the smaller dust extraction units available, testing has shown that the vacuum lasts up to 10 times longer on the KR2 without service or repair work.

Two electric or pneumatic tools can be connected to the unit with RUPES flexible suction hoses. The integrated cabinet can be used for storing tools and accessories. The perforated board with supports provides quick access to consumables. Supplied with hose assembly 5 m Ø 29 mm electric, Swing arm, Hose/Cable holder, Storage bay, 2-way union complete with 1 clapet valve, Perforated board with hooks set 10 pcs, Reel holder, Dust bag (3 pcs.) 016_1612 and Air pressure regulator

RUPES tools and accessories (pictured) sold separately.



RUKR2A	
Power W	2x1500
Weight Kg	115
Vacuum level max mm/H ₂ O	2400
Noise dB(A)	65
Tank capacity L	23
Flow capacity m ³ /h	250
Filter surface m ²	1
Connectable Tools Nr	2
Working pressure bar	6
Manual filter cleaning	√
Filter performance LED	√
ID vacuum nozzle mm	50
Size (hxxwxd) cm	136x98x62





Centralised Dust Extraction System

RUHE501KIT
RUPES 3kW 4Hp Turbine Centralised Dust Extraction System

Thinking Centralised Dust Extraction?

Think HE501 - the high performance RUPES 4Hp Turbine Centralised Dust Extraction System you can install yourself. Low maintenance, reliability and long lifetime. Ideal for up to 4 operators and for distances up to 30/35m. Optimised for prolonged use or to be used during several shifts. Designed for safe working in potentially explosive atmospheres, up to zone 22 (ATEX 99/92/CE).

Features: Automatic start-up, 50L Tank Capacity, Front door for easy removal of dust container, Extremely low noise levels and no vibration, Services up to 4 Electric or Pneumatic Tools, Can be expanded to up to 6 tools

Complete System includes: 1 x HE501 4Hp Turbine with pump side channel, 2 x PE2A Automatic Multi-functional Service Terminals and 20 Metre Installation Kit (includes all fittings to connect wall units to turbine).



HE501	
Weight Kg	135
Filter cleaning: electronic control Rotorjet system	√
Automatic start-up	√
Multifunction display	√
Tank Capacity L	50
ID vacuum nozzle mm	75
Noise dB(A)	65
Filter surface m ²	4
Tools Nr	3/4
Working Pressure Bar	6
Automatic Filter Cleaning	√
Size (hwxwd) cm	138 x 98 x 55
Flow capacity m ³ /h	390
Vacuum Max mm/H ₂ O	2900
Electrical Supply	380V 3ph
Power W/hp	3000/4
Pump side channel technology	√



RUPES PNEUMATIC TOOLS

RURE21A / RURE21AC / RURE21ALN
RUPES Pneumatic Orbital Palm Sanders

These models mirror, in pneumatic, the technical features of the RUPES Electric Palm Sander RULE21A and are suitable for metal, wood working and painted surfaces. These pneumatic palm sanders are extremely compact, and combine great power with a high abrasive capacity. Equipped with a speed regulator and a connection to a RUPES external dust extraction system.

	RURE21A	RURE21AC	RURE21ALN
Ø Orbit mm	3	3	3
Pad size mm	80x130	80x130	70x198
Velcro Base	√	√	√
Operating Pressure Bar	6	6	6
R.P.M	0 - 11000	0 - 11000	0 - 11000
Air consumption Max l/min	360	360	360
Weight kg	0.85	0.87	0.85
Speed Control	√	√	√
Clips for Abrasives			√



Recommended Pads

Code	Ø mm	Interface	Holes
986003	80x130	Velcro	8
988001	70x198	Velcro	Multi-hole

RUSLP41A
RUPES Pneumatic Long-Base Orbital Sander

The power, the diameter of the orbit and the shape of the baseplate enables fast removal of material, a good surface finish and excellent "flattening off" on a large flat surfaces. Equipped with a speed regulator and a connection to a RUPES external dust extraction system with an air flow regulation valve to control the suction effect.

RUSLP41A	
Ø Orbit mm	4.8
Pad size mm	70x400
Velcro Base	✓
Operating Pressure Bar	6
R.P.M	4000-10000
Air consumption Max l/min	400
Weight kg	2.4
Speed Control	✓



Recommended Pads

Code	Ø mm	Interface	Holes
619153	70x400	Velcro	14



Random Orbital Sanders

RURA75
RUPES Pneumatic 75mm Random Orbital Palm Sander

Extremely light and very accurate, designed for quick work on small flat and curved surfaces. Supplied with soft pad to improve the performance of fine abrasives. Tool body designed to provide optimum visibility of parts being worked on. Continuous speed regulation valve.

RURA75	
Ø Orbit mm	3
Pad size mm	75
Velcro Base	✓
Operating Pressure Bar	6.2
R.P.M	0 - 11000
Air consumption Max l/min	380
Weight kg	0.68
Speed Control	✓



Recommended Pads

Code	Ø mm	Interface	Holes
990003	75	Velcro	0



RURA150A
RUPES Pneumatic 150mm Random Orbital Palm Sander

Modern, powerful, light weight design capable of maintaining a constant speed even under stress. Equipped with anti-spinning system to reduce the undesired rotation of the pad and protect the surface from scratches, speed regulator, and shaft locking system for quick pad replacement. Fitted with a slimline pad to reach smaller areas. 5mm Orbit. Connects to a RUPES external dust extraction system.

RURA150A	
Ø Orbit mm	5
Pad size mm	150
Velcro Base	✓
Operating Pressure Bar	6.2
R.P.M	0 - 11000
Air consumption Max l/min	380
Weight kg	0.95
Speed Control	✓



Recommended Pads

Code	Ø mm	Interface	Holes
981425	150	Velcro	Multihole Slim
981410	150	Velcro	6 + 8 + 1





RUA200A
RUPES Pneumatic 200mm Planetary Sander

Forced rotation random orbital machine with gearing technology intended for roughing jobs and fast removal of material, including paint stripping and gelcoats from boats. This agile and light machine allows surfaces to be prepared for finishing quickly and quietly without overheating or excessive surface aggression. With continuous speed adjustment. Fitted with anti-spinning system that progressively accelerates the backing plate during start-up, protecting the surface from scratches. Connects to a RUPES external dust extraction system.



RUA200A	
Ø Orbit mm	5
Pad size mm	200
Operating Pressure Bar	6.2
Stroke per min	4900-11200
Air consumption Max l/min	400
Weight kg	2.3
Speed Control	√

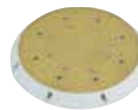

Recommended Pads

Code	Ø mm	Interface	Holes
912279	200	Velcro	8



RURH353A / RURH356A / RURH359A
RUPES 'Skorpio III' Pneumatic Random Orbital Palm Sanders

The Skorpio III is what every random orbital sander operator needs, an extremely quiet tool that has tremendous power and low vibration.

The newly designed pneumatic Skorpio III is the quietest random orbital sander in its class. Further, it comes in a choice of orbit sizes to fit your particular application. The body is coated with an anti-slip rubber for better handling, the throttle lever is designed to support the operator's wrist during operation, the internal balancing of the components results in extremely low vibration and the double row bearings insure greater life and smoother operation. Fitted with a slimline pad to reach smaller areas. Connects to a RUPES external dust extraction system.

	RURH353A	RURH356A	RURH359A
Ø Orbit mm	3	6	9
Pad size mm	150	150	150
Velcro Base	√	√	√
Operating Pressure Bar	6.2	6.2	6.2
R.P.M	0 - 11000	0 - 11000	0 - 11000
Air consumption Max l/min	340	340	340
Weight kg	0.8	0.8	0.8
Speed Control	√	√	√

Renowned for decades for producing the best tools in the body shop industry, the new RUPES SKORPIO III sander is packed full of technical features and design advances:



New Heavy Duty Motor

The new high performance motor built in sintered steel is designed to provide the best power to weight ratio with a lower air consumption. Designed to minimize tool noise and to low vibration level, the new motor reduces internal friction for a higher power transfer ratio, simplified maintenance and longer tool life.



Double Row Ball Bearings

A new double-row ball bearing system, designed specifically by the RUPES Research and Development team, results in longer bearing life, greater motor stability and lower vibration levels.



Anti Spinning System

The presence of the rubber shroud prevents the tool from operating in free rotation mode. This eliminates the risk of damage to the work surface from a true rotary motion. Further, the shroud allows for more efficient dust extraction by sealing the area between the tool's housing and the backing pad.



Recommended Pads

Code	Ø mm	Interface	Holes
981500	150	Velcro	Multihole Slim



WIRBEL

Industrial Wet & Dry Vacuums

Wirbel is a leading European brand of affordable, high quality, industrial strength vacuum cleaners. These high performance wet and dry vacuums offer large capacity and are supplied with metal wand, hose and cleaning head / attachments and 10m cable.

WIR829P / WIR829I / WIR829IRE

Wirbel 829 Wet & Dry Vacuums

Model 829 is a high performance, low noise wet and dry vacuum with compact size. With a 1000 watt motor this vacuum is both quiet and powerful. The tank is mounted on an ABS base which is easily transportable with 4 rotating castors. Paper filter bag. Standard accessories include hose, squeegee tool, floor tool, round brush, crevice tool.

RE Models include an electrical socket designed for use in combination with power tools. Auto / manual start feature.

WIR829	
Rated Power W	1000
Tool Power, max W	1100
Noise dB(A)	65
Capacity L	18
Vacuum mbar	210
Rated Dust Class	L
Electrical Outlet for Tools	RE Versions
Connector Attachment	40mm
Max. air flow rate l/sec	45
Weight Kg	9 (P) / 9.6 (I)
Dimensions cm	34x34x73

Available Versions:

WIR829P Plastic tank
 WIR829I Stainless steel tank
 WIR829I RE Stainless steel tank, electrical socket.



WIR931I

Wirbel 931I Wet & Dry Vacuum

The 931I model is a compact high performance, low noise wet and dry vacuum with stainless steel tank mounted on a fully tipping chassis for ease of emptying. Frame with two fixed wheels and two rotating castors. Paper filter bag. Standard accessories include hose, squeegee tool, floor tool, round brush, crevice tool.

WIR931I	
Rated Power W	1300
Tool Power, max W	1450
Noise dB(A)	68
Capacity L	30
Vacuum mbar	230
Rated Dust Class	L
Connector Attachment	40mm
Max. air flow rate l/sec	55
Weight Kg	15
Dimensions cm	48x58x88



WIR938IRE
Wirbel 938IRE Wet & Dry Vacuum



The 938 model is the most powerful Wirbel Wet and Dry vacuum in our range, with 1500W power. With a stainless steel waste tank mounted on a fully tipping chassis for ease of emptying, and 2 fixed wheels and 2 rotating castors. The special 3-stage high output motor ensures low noise levels. Standard accessories include hose, squeegee tool, floor tool, round brush, crevice tool.

RE Models include an electrical socket designed for use in combination with power tools. Auto / manual start feature.



WIR938	
Rated Power W	1500
Tool Power, max W	1700
Noise dB(A)	62
Capacity L	40
Vacuum mbar	250
Rated Dust Class	L
Electrical Outlet for Tools	RE Versions
Connector Attachment	40mm
Max. air flow rate l/sec	65
Weight Kg	23
Dimensions cm	48x48x88

WIRWD80
Wirbel WD80.21 Industrial Twin Motor Wet & Dry Vacuum



The most powerful vacuum in this range, equipped with 2 powerful and high efficiency New generation motors separately switchable. Stainless steel container. Equipped with new, robust metal trolley. Little weight and compact dimensions with high level performances. Exhaust air filter. With a stainless steel waste tank mounted on a robust tipping chassis for ease of emptying, and 2 fixed wheels and 2 rotating castors. Comes complete with metal wand, hose and cleaning head/attachments and 10m cable.



WIRWD80	
Rated Power W	2500
Noise dB(A)	62
Capacity L	56
Vacuum mbar	230
Max. air flow rate l/sec	115
Weight Kg	20
Dimensions cm	61x52x92

WIRW1
Wirbel W1 Backpack Vacuum



A compact, light, manageable and powerful backpack vacuum. Wear it on your back, so your hands are free, it doesn't hamper movements and allows you to get the job done faster, and more effectively. Double filtration system: cartridge filter + paper filter bag. Exhaust air filter. Motor thermal protection. **Not suitable for wet vacuuming.**

Standard Accessories: Flexible hose 1.5m, Telescopic tube, Extension tube, Dry floor tool, Upholstery tool, Crevice tool, Cartridge filter, textile filter.



WIRW1	
Rated Power W	1350
Noise dB(A)	60
Capacity L	3.3
Vacuum mbar	290
Weight Kg	4.8

WIRCE11**Wirbel CE11 Shampoo Carpet and Upholstery Cleaner Vacuum with Pump**

Compact model, perfect for cleaning carpets, upholstery and car interiors. Three modes of cleaning: vacuum, wash and dry to deliver instant and remarkable cleaning results on all types of textile surfaces. Equipped with stainless steel container and powerful vacuum motor, it can deliver impressive cleaning results. With two fixed wheels and two rotating castors. Complete with flexible hose, 2 x integrated suction tubes, floor tool, hand tool and funnel.

	CE11/1 I
Rated Power W	1300
Noise dB(A)	60
Solution Tank Capacity L	7
Recovery Tank Capacity L	22
Vacuum mbar	240
Max. air flow rate l/sec	55
Weight Kg	11
Dimensions cm	50x38x48

**WIRCE35****Wirbel CE35 Shampoo Carpet and Upholstery Cleaner Vacuum with Pump**

Equipped with a powerful independent 48W pump to produce 55 L/sec of water. Three modes of cleaning: vacuum, wash and dry to deliver instant and remarkable cleaning results on all types of textile surfaces. Equipped with stainless steel container and powerful vacuum motor, it can deliver impressive cleaning results. With two fixed wheels and two rotating castors. Complete with flexible hose, 2 x integrated suction tubes, floor tool, squeegee tool, upholstery tool, hand spray tool, round brush and crevice tool.

	CE35/1 I
Rated Power W	1200
Noise dB(A)	60
Solution Tank Capacity L	12
Recovery Tank Capacity L	35
Vacuum mbar	240
Max. air flow rate l/sec	55
Weight Kg	17
Dimensions cm	65x49x82

**WIRCE56****Wirbel CE56/2 Shampoo Carpet and Upholstery Cleaner Vacuum with Twin Pumps**

Incorporates a pair of independent twin 60W pumps to produce 4.25 L/min of water at 6 bar pressure. Three modes of cleaning – vacuum, wash and dry to deliver instant and remarkable cleaning results on all types of textile surfaces. Equipped with stainless steel tank and powerful vacuum motor 2500W. With two fixed wheels and two rotating castors. Complete with 3m suction hose, hand spray tool, and floor tool.

	CE56/2 I
Rated Power W	2500
Noise dB(A)	62
Solution Tank Capacity L	12
Recovery Tank Capacity L	80
Vacuum mbar	230
Max. air flow rate l/sec	115
Weight Kg	25
Dimensions cm	73x52x92



PNEUTREND INDUSTRIAL QUALITY AIR TOOLS

Sanders & Polishers

PN-55010 10x330mm Belt Sander

Shock absorbing belt guidance. Adjustable 360° swivel sanding arm. Handle air exhaust.



Speed R.P.M	18000
Air consumption	80 LPM (2.8cfm)
Air Inlet	1/4"
Noise LpA / LwA	86/97 DB
Length mm	260
Weight Kg	0.9

PN-55020 20x520mm Belt Sander

Shock absorbing belt guidance. Adjustable 360° swivel sanding arm. Handle air exhaust.



Speed R.P.M	18000
Air consumption	80 LPM (2.8cfm)
Air Inlet	1/4"
Noise LpA / LwA	88/99 DB
Length mm	340
Weight Kg	1.2

PN-54051A High Speed Sander

125mm. Ergonomic, gearless. Handle air exhaust.



Speed R.P.M	18000
Pad Size mm	125
Air consumption	88 LPM (3.1cfm)
Air Inlet	1/4"
Noise LpA / LwA	79.5/90.5 DB
Weight Kg	1.0

PN-52531-H 75mm Palm Sander

Low profile for easy control. Durable & ergonomic design. Variable speed. 2.5mm Orbit. 75mm Velcro pad.



Speed R.P.M	0-12000
Pad Size mm	75
Orbit mm	2.5
Spindle	5/16"
Air consumption	62 LPM (2.2cfm)
Air Inlet	1/4"
Noise LpA / LwA	75/86 DB
Weight Kg	0.8

PN-52362-H 150mm Palm Sander

Durable, low profile design for easy control. 5mm Orbit. 150mm Velcro pad.



Speed R.P.M	10000
Pad Size mm	150
Orbit mm	5
Air consumption	62 LPM (2.2cfm)
Noise LpA / LwA	75/86 DB
Weight Kg	0.9

PN-52562-H 150mm Palm Sander

Durable, low profile design for easy control. Variable speed. 2.5mm Orbit for general sanding 150mm Velcro pad.



Speed R.P.M	0-12000
Pad Size mm	150
Orbit mm	2.5
Air consumption	62 LPM (2.2cfm)
Air Inlet	1/4"
Noise LpA / LwA	75/86 DB
Weight Kg	0.96

PN-54106 / PN-B-54106 75mm Disc Sander / Kit

Compact design. Durable and lightweight. Ergonomic pistol grip. Variable speed for maximum control.

PN-54106 Sander
PN-B-54106 Kit (Pictured)



Speed R.P.M	18000
Pad Size mm	75
Air consumption	76 LPM (2.7cfm)
Air Inlet	1/4"
Noise LpA / LwA	78.1/89.1 DB
Weight Kg	0.53

PN-50006 3" Mini Pistol Polisher

Durable and lightweight. Ergonomic pistol grip. Low-noise. Variable speed for maximum control. Includes 3" Pad.



Speed R.P.M	Max 5000
Spindle	5/16"
Power	0.28KW (0.38HP)
Air consumption	76 LPM (2.7cfm)
Air Inlet	1/4"
Noise LpA / LwA	78.4/89.4 DB
Length mm	140
Weight Kg	0.68

PN-50074 3" Extension Angle Polisher

For work in confined areas. Variable speed. Includes 75mm Velcro pad.



Speed R.P.M	0-2300
Spindle	5/16"
Power	0.22KW (0.3HP)
Air consumption	60 LPM (2.1cfm)
Air Inlet	1/4"
Noise LpA / LwA	85/95 DB
Length mm	170
Weight Kg	0.7

PN-50075 7" Angle Polisher

Compact and lightweight. Variable speed safety-lock lever throttle. Uses 125mm to 200mm pads. Rear exhaust. Soft-grip handle can be positioned for right or left hand operation.



Speed R.P.M	0-2500
Spindle	M14 x 2.0
Power	0.52KW (0.7HP)
Air consumption	89 LPM (3.1cfm)
Air Inlet	1/4"
Noise LpA / LwA	82.6/93.6 DB
Length mm	305
Weight Kg	2.2

PN-50180 3" Random Orbital Polisher

14mm Orbit. Digital series. Polishes out sanding scratches. Right or left hand operation. Rear exhaust muffler reduces sound levels.



Speed R.P.M	Max 12000
Power	0.26KW (0.35HP)
Air consumption	62 LPM (2.2cfm)
Air Inlet	1/4"
Noise LpA / LwA	78.1/89.1 DB
Length mm	252
Weight Kg	1.2

Drills and Other

**PN-33106
3/8" In-Line Drill**

For low speed and high torque applications. Rear exhaust.



Chuck Size	3/8"
Speed R.P.M	2600
Spindle Thread	3/8"-24
Air consumption	99 LPM (3.5cfm)
Air Inlet	1/4"
Noise LpA / LwA	82.9/93.9 DB
Length mm	225
Weight Kg	0.78

**PN-33120
3/8" Right Angle Drill**

For drilling in confined areas. 6-blades-rotor. Handle air exhaust.



Chuck Size	3/8" x 24
Speed R.P.M	1900
Drill Size	1/4" (6 mm)
Air consumption	60 LPM (2.1cfm)
Air Inlet	1/4"
Noise LpA / LwA	87.0/98.6 DB
Length mm	195
Weight Kg	1.1

**PN-33202A
3/8" Reversible Air Drill**

Easy 2-step trigger control. Comfortable grip handle. Handle air exhaust.



Drive	3/8"
Speed R.P.M	1800
Spindle Thread	3/8"-24
Air consumption	71 LPM (2.5cfm)
Air Inlet	1/4"
Noise LpA / LwA	94.9/105.9 DB
Length mm	190
Weight Kg	1.1

**PN-34202A-1
1/2" H.D Reversible Drill**

2 Step trigger easy control. Comfortable grip handle. Handle air exhaust.



Chuck Size	3/8" x 24
Speed R.P.M	900
Drill Size	1/2" (13 mm)
Air consumption	71 LPM (2.5cfm)
Air Inlet	1/4"
Noise LpA / LwA	75 DB
Length mm	205
Weight Kg	1.7

**PN-33500
Spot Weld Drill with Hook**

Comes with 2" arm & 8 mm cutter. Rear exhaust. Additional arms available.

PN-33500 Drill
PN-33500-50A 3" Hook Arm
PN-33500-50B 5.5" Hook Arm



Speed R.P.M	1600
Air Inlet	1/4"
Air consumption	71 LPM (2.5cfm)
Noise LpA / LwA	92.8/103.8 DB
Length mm	300
Weight Kg	2.1

**PN-33501
Spot Weld Drill with Hook**

2 Step adjustable depth. Optional HSS drill bits size 6.5 and 10 mm. Rear exhaust.



Speed R.P.M	1400
Air Inlet	1/4"
Air consumption	57 LPM (2.0cfm)
Noise LpA / LwA	79.8/88.8 DB
Length mm	310
Weight Kg	1.8

**PN-41102H
190mm Barrel Air Hammer**

Cushion grip handle. 10mm Hexagon chisel shank. Front air exhaust.



Chisel Shank	10mm (0.4")
Speed B.P.M	3500
Stroke	66mm
Bore Dia.	19mm
Air Inlet	1/4"
Air consumption	56 LPM (2cfm)
Noise	103 DB (A)
Length mm	170
Weight Kg	1.5

**PN-82126
3/16" Air Hydraulic Blind Riveter**

Sets rivets in all materials in from 2.4mm to 4.8mm. Sizes of Nose pieces: 2.4 mm, 3.2 mm, 4.0 mm & 4.8 mm



Stroke	14mm
Air Inlet	1/4"
Air consumption	0.55 CFM
Noise LpA / LwA	79.7/90.7 DB
Length mm	270
Weight Kg	1.8

**PN-82015
Surface Preparation Tool**

For removing seam sealer, rust, corrosion, paint, protective coatings. Paddle Style Trigger. Rear exhaust. Rubber eraser wheel sold separately.



Speed R.P.M	3500
Air consumption	88 LPM (3.1cfm)
Air Inlet	1/4"
Noise LpA / LwA	82.3/93.3 DB
Length mm	277
Weight Kg	1.0

**PN-B-82018K
Surface Preparation Tool Kit**

Excellent for removing seam sealer, rust, corrosion, paint, protective coatings, etc. Rubber eraser wheel for pinstripe and graphics removal. Paddle Style Trigger for precise speed control. Integrates with external dust extraction system for safe and clean operation. Rear exhaust.



Speed R.P.M	3500
Air consumption	82 LPM (3.1cfm)
Air Inlet	1/4"
Noise LpA / LwA	82.3/93.3 DB
Length mm	277
Weight Kg	1.0

- Kit includes:
- 1 x Surface Preparation Tool (Central-Vacuum) 82018
 - 1 x Hub for Eraser / Wheel A3020
 - 1 x Wire Wheel (Steel, Straight Tip) 100mm OD x 23mm W x 0.5mm A3201-MWI
 - 1 x Wire Wheel (Steel, Bent Tip) 100mm OD x 23mm W x 0.5mm A3200-MWI
 - 1 x Wire Wheel (Steel, Bent Tip) 100mm OD x 23mm W x 0.7mm A3200-CWI
 - 1 x Eraser Wheel 105mm OD x 30mm W A3012-1
 - 1 x Stripping Wheel 110mm OD x 30mm W A3014-1
 - 1 x Blow Mould Case

Wrenches

**PN-12202
Pneutrend 3/8" Ratchet Wrench**

Durable, variable speed and reversible air ratchet. The paddle style trigger provides precise speed control.



Speed R.P.M	175
Drive	3/8"
Max. Torque	68Nm (50ft-lb)
Air Inlet	1/4"
Air consumption	80 LPM (2.8cfm)
Noise LpA / LwA	82.8/93.8 DB
Length mm	265
Weight Kg	1.2

**PN-23101
Pneutrend 3/8" Butterfly Impact Wrench**

360 degree rotary air connection. Butterfly throttle for single hand control. Side exhaust. Rocking dog clutch.



Speed R.P.M	10000
Drive	3/8"
Max. Torque	102Nm (75ft-lb)
Air Inlet	1/4"
Air consumption	100 LPM (3.5cfm)
Noise LpA / LwA	99.1/110.1 DB
Length mm	171
Weight Kg	1.1

**PN-13216
Pneutrend 3/8" Stubby Ratchet Wrench**

Great for small jobs. Handle rotation air exhaust.



Speed R.P.M	250
Drive	3/8"
Max. Torque	41Nm (30ft-lb)
Air Inlet	1/4"
Air consumption	80 LPM (2.8cfm)
Noise LpA / LwA	85.8/96.8 DB
Length mm	165
Weight Kg	0.5

**PN-14201B
Pneutrend Palm Ratchet Wrench**

Handle air exhaust. Ideal for confined spaces.



Speed R.P.M	300
Drive	1/4"
Max. Torque	30Nm (22ft-lb)
Air Inlet	1/4"
Air consumption	110 LPM (3.9cfm)
Noise LpA / LwA	85.0/96.0 DB
Length mm	125
Weight Kg	0.45

**PN-22106
Pneutrend 1/4" Mini Air Impact Wrench**

Compact design. Durable and lightweight body. Ergonomic pistol grip with trigger control. Convenient fingertip reverse. Twin dog clutch.



Speed R.P.M	15000
Drive	1/4"
Max. Torque	68Nm (50ft-lb)
Air Inlet	1/4"
Air consumption	51 LPM (1.8cfm)
Noise LpA / LwA	80.1/91.1 DB
Length mm	137
Weight Kg	0.71

**PN-24230
Pneutrend 1/2" Mini Air Impact Wrench**

Composite light weight handle for improved comfort. Handle exhaust. 4 Speed forward power setting and max. power in reverse. Twin hammer clutch.



Speed R.P.M	12000
Drive	1/2"
Max. Torque	542Nm (400ft-lb)
Air Inlet	1/4"
Air consumption	65 LPM (2.3cfm)
Noise LpA / LwA	95.0/106.0 DB
Length mm	149
Weight Kg	1.3

**PN-24237
Pneutrend 1/2" Mini Air Impact Wrench**

Composite housing and lightweight body. High performance twin hammer mechanism. 360° Swivel air inlet. Sensitive trigger for smooth operation.



Speed R.P.M	11000
Drive	1/2"
Max. Torque	680Nm (500ft-lb)
Air Inlet	1/4"
Air consumption	120 LPM (4.2cfm)
Noise LpA / LwA	85.2/96.2 DB
Length mm	160
Weight Kg	1.3

**PN-A2305T
Pneutrend Grease Dispenser Head with Grease**

Servicing kit for the long-life maintenance of Twin-hammer impact systems. 100g (3.5 oz) grease tube. With 30° and 90° Grease Tip.



**PN-B-13230K
Pneutrend Thru-Hole Ratchet Wrench Kit**

The thru-hole socket and extenders eliminate the need for deep socket. Simple flip ratchet head to change directions.

26 Piece Kit includes:
1 x Stubby Thru-hole Ratchet Wrench
1 x 1/4" Bit Holder
3 x Adaptors : 1/4", 3/8" & 1/2" Dr.
1 x Carry Case
10 x Thru-hole Sockets:
(8,10,12,13,14,15,16,18,19 & 21 mm)
or
(5/16",3/8",7/16",1/2",9/16",5/8",
11/16", 3/4" & 13/16")
10 x Bits: (#1, #2, #3, Hex, 4mm, Hex,
6mm, Slot 4.5 mm, Slot 7mm, Star 25,
Star 30 & Star 40)



Drive	1/4"
Max. Torque	41Nm (30ft-lb)
Air Inlet	1/4"
Air consumption	87 LPM (3.1cfm)
Noise LpA / LwA	93.0/104.0 DB
Length mm	130
Weight Kg	0.55

**PN-B-24200K
Pneutrend 1/2" Impact Wrench Kit**

Composite lightweight handle for improved comfort. Handle exhaust. 4 Speed forward power setting and max. power in reverse. Twin hammer clutch.

Kit includes:
1 x 24200 1/2" Impact Wrench
3 x Sockets (17mm, 19 mm & 21 mm)
1 x Carry Case



Drive	1/2"
Speed R.P.M	8000
Max. Torque	880Nm (650ft-lb)
Air Inlet	1/4"
Air consumption	113 LPM (4.0cfm)
Noise LpA / LwA	95.9/105.9 DB
Length mm	184
Weight Kg	2.2

Die Grinders

**PN-71300
Pneutrend Heavy Duty Die Grinder**

Rugged design ideal for rapid metal removal, deburring with either a mounted wheel or rotary burr. Durable. Unique device for quick change between front and rear exhaust.



Speed R.P.M	25000
Collet	6mm (1/4")
Power	0.3KW (0.4HP)
Air Inlet	1/4"
Noise LpA / LwA	79.1/90.1 DB
Length mm	155
Weight Kg	0.5

**PN-74100
Pneutrend 1/4" Die Grinder - PneuDigit Series**

Digital pressure display. Angle head design permits access to difficult to reach areas. Rear exhaust for low noise.



Speed R.P.M	20000
Collet	6mm (1/4")
Power	0.22KW (0.3HP)
Air consumption	57 LPM (2.0cfm)
Air Inlet	1/4"
Noise LpA / LwA	78.4/89.4 DB
Length mm	185
Weight Kg	0.62

**PN-71000
Pneutrend 1/4" Die Grinder**
6mm Collet. Power regulator. Cushion grip. Handle exhaust.



Speed R.P.M	22000
Collet	6mm (1/4")
Power	0.37KW (0.5HP)
Air consumption	62 LPM (2.2cfm)
Air Inlet	1/4"
Noise LpA / LwA	87/98 DB
Length mm	177
Weight Kg	0.6

**PN-82101
Pneutrend Punch & Flange Tool**

8mm Punch. 1.6mm Flange capacity.



Flange mm	1.6
Punch mm	8
Air consumption	6 LPM (0.2cfm)
Length mm	135
Weight Kg	0.25

Cutting & Grinding Tools

**PN-80010
Pneutrend 3" Cut Off Tool**

Handle air exhaust. With protection cover.



Speed R.P.M	20000
Wheel Size	75mm
Air consumption	65 LPM (2.3cfm)
Air Inlet	1/4"
Noise LpA / LwA	88.6/99.6 DB
Length mm	190
Weight Kg	0.8

**PN-80004
Pneutrend Low-Noise In-Line Metal Shear**

For trimming and cutting sheet metal. Heavy-duty cutting blades make clean cut in cold rolled steel up to 20-gauge. Rear exhaust. 1.2mm Cutting capacity for Steel Sheet. 1.6 mm Cutting capacity for Aluminium Sheet.



Speed R.P.M	2600
Air consumption	99 LPM (3.5cfm)
Air Inlet	1/4"
Noise LpA / LwA	80/91 DB
Length mm	240
Weight Kg	1.0

**PN-75003
Pneutrend 5" Angle Grinder**
Side air exhaust. Safety lever. Side handle.



Speed R.P.M	11000
Capacity	125mm
Spindle Size	M10, M14, 3/8"-24
Air consumption	99 LPM (3.5cfm)
Air Inlet	1/4"
Length mm	230
Weight Kg	1.8

**PN-80016
Pneutrend Low-Noise 4" Angle Cutter**

Low profile for working in restricted areas. Lightweight design prevents from fatigue.



Speed R.P.M	11000
Wheel Size	4"
Air consumption	99 LPM (3.5cfm)
Air Inlet	1/4"
Noise LpA / LwA	84.4/95.4 DB
Shaft Length mm	71
Weight Kg	1.0

**PN-80033
Pneutrend Air Body Saw**

Low vibration. Designed for all types of cutting. Handle exhaust. Cushion grip.



Stokes per min.	5000
Stroke	10mm
Air consumption	160 LPM (5.6cfm)
Air Inlet	1/4"
Noise LpA	70 DB
Length mm	275
Weight Kg	1.0

**PN-80037 / PN-B-80037K
Pneutrend Air Body Saw / Kit**

Low vibration. Powerful saw allows you to cut off the material easily. Guide to preset the cutting depth. Includes 1 x 18T/ 24T/ 32T Bi-Metal Saw Blades.



PN-B-80037 Kit pictured includes: PN-80037 Air Saw, 5x24T Blades, 5x32T Blades, 4x Triangle, Round, Half Round, Flat File (each), Dial Regulator, T Handle Key Wrench and Blow Case.

Strokes per min.	10000
Stroke	10mm
Air consumption	65 LPM (2.3cfm)
Air Inlet	1/4"
Noise LpA / LwA	76.5/87.5 DB
Length mm	193
Weight Kg	0.7

**PN-80018
Pneutrend Low-Noise 4" Angle Cutter**

Unique low profile design suitable for tight areas. Versatile cutting capability for any applications.



Speed R.P.M	11000
Wheel Size	4"
Air consumption	99 LPM (3.5cfm)
Air Inlet	1/4"
Noise LpA / LwA	83.6/94.6 DB
Shaft Length mm	220
Weight Kg	1.2

SPRAY EQUIPMENT



Touch Up Spray Gun
WYA-FR200 1.0mm



1 Litre Suction Spray Guns
WYA109-035-1.4 1.4mm
WYA109-035-2.0 2.0mm



Gravity Feed Spray Guns
WYA298-003-1.4 1.4mm
WYA298-003-1.7 1.7mm



WorkQuip Gravity Feed Spray Gun Kit
Includes 1.4mm, 1.8mm and 2.5mm setup.
WKQUIPGRAVITY



2 Litre Pressure Feed Spray Gun
WYA-H829W



Air Spray Gun Suction Feed
1.5mm. With 1L Aluminium cup.
WYA089-071



HVLPAir Gravity Feed Spray Gun Kit
1.0/1.4mm. Capacity 600/125cc
WYA238-032



WorkQuip Spray Gun Kit
Includes 1.8 and 2.5mm Stainless steel fluid nozzle. 1L dripless spray pot.
WKQUIPHIGH



2 1/4 Gallon Pressure Pot with 1.2mm Spray Gun
WYA5P-156



2 Litre Pressure Pot
WYA060-010



4 Litre Pressure Pot
WYA060-001



2 Litre Air Wax Sprayer
WYA016-047 1.4mm



9" Caulking Gun
7.2 Volt.
WYA-C0024-008



Air Boy Underseal Gun
1.2L Capacity. Made in Denmark.
AIUSG 1.2L Gun
AIUSGE Gun Extension



Air Spray Seam Sealer Gun
WYA150-033



Pneutrend Undercoating Gun
Suitable for applying protection and sound proofing treatments.
PN-82200



Industrial Mini Pump Spray Bottle
1 Litre capacity.
WYA040565



Air Boy Dust Gun
Made in Denmark.
AIDG



Pneutrend Digital Regulator
Digital pressure display helps provide precise colour matches & reduce orange peel.
PN-A2099



18 Piece Spray Gun Cleaning Set
WYA115-076

Air / Pneumatic Fittings



Premium Thread Seal Tape
THREAD

Band-it Clamp
21/9.5mm V201
AR500



Coupler Standard 1/4"
AR210



Coupler High Flow 1/4"
AR380



Coupler High Flow 3/8"
AR3803-8



Hose Tail Piece Standard Male 1/4"
AR111



Hose Tail Piece Standard Male 3/8"
AR116



Hose Tail Piece Standard Male 1/4"
AR2608



Hose Tail Piece Standard 10mm
AR3948



Hose Barb Tail Piece High Flow
AR3810



Tail Piece Standard Female 1/4"
AR2609



Tail Piece Standard Male 3/8"
AR2700



Tail Piece High Flow Female 1/4"
AR3812



Tail Piece High Flow Female 3/8"
AR3809



Tail Piece High Flow Male 1/4"
AR3807



Tail Piece High Flow Male 3/8"
AR3808



Tail Piece 1/4" Swivel High Flow Female
ARFP6-2F



Tail Piece Swivel High Flow Male 1/4"
ARFP6-2M



Rubber Airline 10mm
Per/M
AR10



Spray Gun Washers

Certified CE and ATEX. Stainless steel. Italian made.

GUNWASH135

RosAuto `135` Mini Spray Gun Washer Combined Water & Solvent

Cleans whole spray-guns, spraying nozzles, paint cup, mixing stirrers, paint filters, etc. Use inside or outside the spray booth. Certified CE and ATEX (ATEX II 2G). Italian made.

One pump with dirty fluid for both zones (prewash). One nebulizer with clean fluid for both zones (final rinse). Brush for manual washing. Works with water plus detergent & thinner. Produces very few gases. Aspiration system built-in. Air gun for drying

- Compact unit: 450 x 310 x 830 mm
- 6-10 bar Air pressure
- 4 Tanks of 5 Litres each

GUNWASH177

RosAuto `177X` Spray Gun Washer for Waterborne Paint

For Waterborne Paint. Manual washing with water.

Pneumatically operated, small and cost-effective machine for manually washing water-based paint from spray guns and small objects. Manual wash with detergent: water and detergent sucked by the small pump are conveyed to the brush for manual wash. Pre-wash with brush and pump fed recirculating liquid. 177X: this special model entirely manufactured in stainless steel is fitted with a brush fed by a diaphragm pump conveying water and detergent.

Final Rinse: One nebulizer sucks clean water from the container housed in the bottom of the machine. The brush supplied must be connected to the water mains of the company and is used for the final wash, for cleaning inside the spray-gun washer, and for pouring clean water in the tanks for the following wash cycle. Finally, the blowing air gun is used to clean inside and dry the guns and the washed parts. Water / paint separation kit included

- 450 x 660 x 1335 mm
- Min 6 - max 10 bar Air pressure
- 50 Litre sink capacity for water
- 1 extra brush can be connected to water supply

GUNWASH182

RosAuto `182CX` Spray Gun Washer for Waterborne Paint

For Waterborne Paint. Automatic and manual washing with water.

The pneumatic Multi-Water spray-gun washer, in stainless steel and with vapour suction, is ideal for washing spray guns stained with water-based paint with top results through:

Automatic washing with water and detergent: this is the first cycle to wash spray-guns, paint drums, mixing rods and paint filters by means of nozzles connected to a diaphragm pump and a timer.

Manual washing with water: During this cycle a small pump and a nozzle suck the clean water from the drum located at the bottom of the machine. The brush supplied must be connected to the water mains of the company and is used for the final wash, for cleaning inside the spray-gun washer, and for pouring clean water in the tanks for the following wash cycle. Finally, the blowing air gun is used to clean inside and dry the guns and the washed parts. Water / paint separation kit included.

- 450 x 685 x 1500 mm
- Min 6 - max 10 bar Air pressure
- 50 Litre sink capacity for water
- Manual and automatic wash of waterborne paint
- 120mm Exhaust duct diameter
- Vapour exhaustion from work area
- 1 x Extra brush can be connected to water supply

GUNWASH165

RosAuto `165` Spray Gun Washer For Water or Solvent-Based Paint

Water Zone: Pre-wash with brush and pump fed recirculating liquid. Nebulizer for final rinse with clean water. 1 extra brush can be connected to water supply. Air gun for final drying. Water/paint separation kit included

Solvent Zone: Pre-wash with Venturi pump fed recirculating thinner. Venturi pump feeding clean thinner. Nebulizer for final rinse with clean thinner. Colour tests allowed. 100% Stainless steel. ATEX II 2G

- 790 x 690 x 1385 mm
- Min 6 - max 10 bar Air pressure
- Automatic vapour exhaustion from work area (150mm Exhaust duct diameter)

SAFETY PRODUCTS

Respiratory Protection

SPE-U351034

Survivair Half Mask Spray Painters Kit

Safety-first protection from hazardous dust, fumes and vapours of spray painting and welding. Made from comfortable, pliable silicone to prevent oxidation and loss of elasticity.

Kit includes:

- Survivair 3000 half mask
- 2 x Organic A2 Vapour cartridges (SPE-100100)
- 2 x P2 prefilters (SPE-101000)
- 2 x Retainers (SPE-140079).

SPE-U764000

Sperian Optifit Convertible Air Purifying Respirator - 5 Strap Suspension Medium

Wide viewing area offering distortion free visibility and optical clarity. 5-point strap. Silicone skirt offers exceptional durability and comfort. Nose cup prevents fogging. Replaceable, high-impact resistant polycarbonate lens treated with anti-scratch coating.

SPE-DMAK-0201

Honeywell Air Visor2 MV Refinishers Spray Kit

SAR with additional spray gun hose assembly and clear acetate visor to protect against chemical splashes. Proven safety solution when you need clean, compressed air from a source outside the contaminated area. Air passes through the airline to the face piece or hood, with continuous flow creating increased pressure which cools the face and reduces fogging.

SPE-DCF-100

Honeywell Willson Respiratory Spray Painters Kit

A complete respiratory protective system that cools the face and reduces fogging, ideal when applying two-pack paint. The air visor has been developed to offer the best protection, comfort and quality.

Features:

- Complete with visor, auxiliary air hose, waist belt and filter
- 7.5m air hose with fittings approved to Australian Standards
- Two person combination filter set, including airline fittings

Accessories available:

- SPE-DHFE-0075 Willson Blueline Air Breathing Hose 7.5m
- SPE-DHFE-015 Willson Blueline Air Breathing Hose 15m
- SPE-DHFE-030 Willson Blueline Air Breathing Hose 30m



PROFESSIONAL HEAT TOOLS

Plastic Welding Tools & Accessories

TRIACST / TRIACAT Leister TRIAC Hot Air Plastic Welding Tools

Plastic welding made easy. All Leister hot air tools are manufactured in Switzerland and meet strict international standards. The TRIAC Hot Air Tools from Leister are primarily used for welding thermoplastics, heating, drying and shrinking, making it ideal for the flooring industry.

Push-fit exchangeable nozzle change. Light and easy to handle - the sturdy, professional hot-air tools that weigh less than 1 kg. Ergonomically designed handle with soft grip covering for secure hold. Electronically protected heating element. Convenient and reliable temperature adjustment. Built-in start-up protection. Model TRIACAT includes a digital display.



	TRIACST	TRIACAT
Temperature C	40° F - 700° F	40° F - 650° F
Power W	1600	1600
Digital Display		✓
Weight Kg	1.0	1.0



Digital Display Temp. Setting (AT Model) 5mm Universal Nozzle Spare Heating Element

TSPWELD / TSWE160172 Weldy Energy Hot Air Plastic Welding Kits

The NEW Energy HT1600 is compact, robust and affordable hot air tool, ideal in a wide range of professional applications. The tool has built-in protection against overheating.

HT1600 D hot-air hand tool is fitted with a powerful blower, and features digital temperature control and setting via the LCD display.

Features:

- Ceramic heating element
- Robust brush motor
- Automatic cool-down function
- Memory settings
- Swiss Technology & Engineering
- CE Conformity

Kit includes:

- Weldy tool HT1600 (analogue) or HT1600 D (Digital)
- 5mm Tubular nozzle
- 4mm Speed Welding Nozzle
- Carry case

	HT1600	HT1600D
Temperature C	40° - 700°	40° - 620°
Power W	1600	1600
Air Volume l/min	180	120-240
Digital Display		✓
Weight Kg	1.0	1.2

TSWE160172 HT1600 D Digital Kit (Pictured)
TSPWELD HT1600 Analogue Kit



PRINZPSW Prima Puntobat Plastic Welder for Staples

Puntobat can repair and strengthen all plastic car parts such as bumpers, dashboard, lights, flaps, fenders and more.



TSLE6600075-SA / TSLE6600070-PA
Techspan Rion Hot Air Plastic Welding Kits

The Techspan Plastic Welder is a high quality, robust tool, designed to withstand the most adverse working conditions, Welding temperature is adjustable up to 650° C. Superior ceramic plug-in element provides superior performance and reliability. Made in Switzerland.

TSLE6600075-SA Rion Analogue Standard Automotive Kit includes:

- LE6600075-SA Hot air tool type Techspan Rion "heavy duty"
- LE100303 Standard Nozzle for Techspan tool – pendulum welding nozzle
- LE106996 Tacking Nozzle – push fit on standard nozzle
- RTK Rod Test Kit – over 40 rods for ID of plastics
- Carry Case (metal case)

TSLE6600070-PA Rion Digital Premium Automotive Kit (pictured) includes:

- LE6600070-PA Hot air tool type Techspan Rion "heavy duty"
- LE100303 Standard Nozzle for Techspan tool – pendulum welding nozzle
- LE106996 Tacking Nozzle – push fit on standard nozzle
- LE106989 Speed Welding Nozzle 3mm Round
- LE28F Rotary Burr bit
- LEDVD Instructional Plastic Welding DVD
- RTK Rod Test Kit – over 40 rods for ID of plastics
- LEPLFIX Plastic Fix Text Book
- Carry Case (metal case)



	LE6600075-SA	LE6600070-PA
Temperature C	60° - 650°	20° - 650°
Airflow l/min	230	250
Output W	1600	1600
Digital Display		✓
Weight Kg	1.5	1.5

STHL1920E
Steinel Professional Electronically Controlled Hot Air Tool

German quality, for unmatched precision and performance. Steinels HL 1920E is a high-precision tool, perfect for welding bumpers and plastics, cable stripping, soft soldering, paint stripping, heating rubber and more. Perfectly balanced tool makes it easy to use with only one-hand. 200 Watts, and an adjustable temperature range. Airflow rate adjustable in three stages.



Temperature C	80° - 600°
Temperature Setting	Variable in 9 increments
Airflow Rate cfm	Setting 1: 150 l / min.
	Setting 2: 150 - 300 l / min.
	Setting 3: 300 - 500 l / min.
Power Consumption W	2000
Power cord Length	2.2m
Weight Kg	0.85



Features:



Well Balanced 3 Stage Air Flow 9 Temperature Fine Dust Filter Settings

STHG2320E
Steinel Professional Electronically Controlled Hot Air Tool

German quality, for unmatched precision and performance. Precision digital control. Electronically controlled HG 2320 E hot air tool, 2300 W, digital temperature setting by joystick from 80 - 650°C, temperature indicated in 10°C steps on LCD display. Airflow regulation in 2 stages of 150 and 500 l/min. The digital precision tool for temperature-critical materials. The 2300 Watt HG 2320 E hot air tool is fitted with a 3 m cable, making it perfectly equipped for jobs that demand greater freedom of movement.

Temperature C	80° - 650°
Airflow Rate cfm	150 - 500 l / min.
Power Consumption W	2300
Power cord Length	3m
Weight Kg	0.755



Plastic Welding Rods & Accessories

Per Unit.
 We can also order any other plastic rods you required.

STHE010370	Steinel 9mm Reduction Nozzle (fits STHG2310LCD and STHG2300E)
TSPP3	Polypropylene 3mm coil 25 metre, Black
TSPP8	Polypropylene 8mm coil 25 metre, Black
TSPP13	Polypropylene 13mm coil 25 metre, Black
TSEPDM3	PP/EPDM 3mm Round 25 metre Black
TSEPDM8	PP/EPDM 8mm Round 25 metre Black
TSEPDM13	PP/EPDM 13mm Round 25 metre Black
TSABS3	ABS 3mm Round 25 metre Coil Black
TSABS8	ABS 8mm Round 25metre Coil Black

INFRARED EQUIPMENT

WYFY-1WH / WYFY2AT / WYFY3WH
Fy Tech Short Wave Infrared Paint Curing Systems

Fully-automatic device, equipped with LED electronic adjustable timer and adjustable power settings. With pulse ultrasonic paint curing function. Hydraulic lifter with an independent switch and 360° rotation. Each emitter can be independently controlled. Automatic overload protection.

WYFY1WH 1 Short Wave Infrared 1000W Halogen lamp
WYFY2AT 2 Short Wave Infrared 1000W Halogen lamps
WYFY3WH 3 Short Wave Infrared 1000W Halogen lamps



WYA042-002
2000 Watt Medium Wave Infrared Curing Machine with Timer
Paint curing machine featuring medium-wave halogen tubes.
Height adjustable stand.

WYFY5000L
Fy Tech Multifunctional Digital Short Wave Infrared Paint Curing Lamp

Equipped with 4 x 1000W short wave infrared halogen tubes. Automatic device with a digital operation panel and LCD display electronic functions. Hydraulic lifter with an independent switch and pivoting head. Regular and pulse preheat curing function. Adjustable temperature range 40-100 C are automatically controlled by easy to use timers (0-99 min) and an automatic distance and temperature sensors allows quick, precise setting of the distance to the panel. Each emitter can be independently controlled. Suitable for curing two-pack and most waterborne paints.



STANDS & STORAGE SOLUTIONS

WYFY802A / WYFY904 / WYFY907E

Fy Tech Tool Cabinets

Heavy duty construction. Drawers equipped with heavy-duty ball bearing slides for long life and stronger extension ability.

- WYFY802A 800 x 485 x 1020mm
- WYFY904 800 x 485 x 1010mm
- WYFY907E 1170 x 485 x 1010mm



WYFY802A



WYFY904



WYFY907E

STANDS & STORAGE SOLUTIONS

WYA1T232
3 Shelf Trolley
 Tray size: 745w x 442d x 75mm h. With wheels.



WYA-C409-002
2 Door Cabinet
 Lockable. With wheels. Size: 650w x 380d x 720mm h.



WYA-C409-003
Tool Cart with 2 Drawers
 Lockable. With wheels.



WYA229-114
Tool Cart with Sliding Top
 Lockable. With wheels.



WYA096-003
48 Drawer Heavy Duty Parts Cabinet
 (CarKlips sold separately.)



OMART250
OMCN Jolly Trolley
 The moving of vehicles without front or rear mechanics is no longer a problem. Nylon wheels.

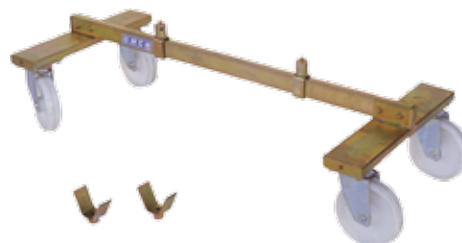

Premium Panel Stands
 Extra wide castors for grated spray booths. Made in USA.

TSTWT10
Fender Stand

TSTBT10
Bumper Stand

TSTHT10
Bonnet Stand

TSTSET
Premium Panel Stands
Set of 3
 Includes Fender Stand, Bumper Stand and Bonnet Stand.



WYA121-034
Side Mirror Stand & Bumper Holder



WYA557-002
Windshield Folding Stand



WYA121-030
Bumper Tree
Full swivel and tilt.



WYA038-014
Bumper Caddy
With wheels.



WYA121-026
Adjustable Folding Stand
Max. width 130cm. Max. height 115cm.



WYA121-020
Wall Mounted Bumper Rack
Holds up to 3 bumpers, K/D Type.



WYA207-001
Panel Stand
Foam cover whole arm.



WYA-C0380-085
Portable Work Stand
Foam padded top



WYA121-059
Tool Seat



Masking Machines

WYA1T272
18" Masking Machine



WYA038-035
36" Masking Machine
Twin roll dispenser. Accepts rolls up to 900mm.



WYA380-208
Masking Film Stand
Fits masking film up to 1.30cm.
Props not included.



Roll Cages, Racks & Stands

WYA121-022
Small Roll Cage
800 x 800 x 1880mm.
(Not pictured.)

WYA121-021
Large Roll Cage
800 x 1240 x 1880mm.

WYA121-023
3 Shelf Parts Stand
740 x 940 x 1900mm.

WYA121-024
2 Shelf Parts Stand
740 x 940 x 1010mm.

WYA121-025
3 Shelf Parts Stand
Wall mounted.
1050 x 850 x 590mm.

WYA121-033
3 Shelf Parts Stand with Rack
940 x 760 x 1850mm.

WYA121-023

WYA121-033

WYA121-021

WYA121-024

WYA121-025



HAND TOOLS

Door Panel Removers



Code	Type
WYA3R-272	Type V
WYA3R-273	Type 
WYA3R-274	Type 

Finishing Hammers

Head weight 305g. Overall length 330mm.



Code	Type
WYA071-002	Curved Pein
WYA071-006	Straight Pein
WYA071-018	Pick & Finishing

Dolly

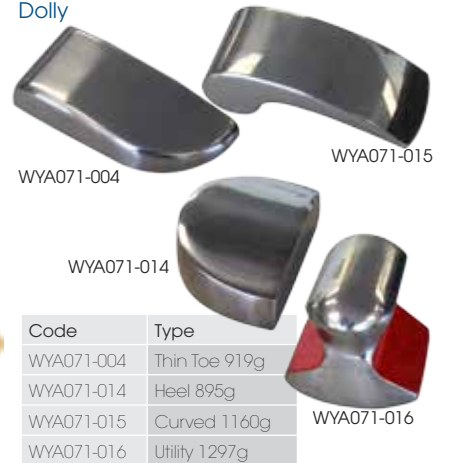

Code	Type
WYA071-004	Thin Toe 919g
WYA071-014	Heel 895g
WYA071-015	Curved 1160g
WYA071-016	Utility 1297g

WYA071-033 Flat Spoon

Light duty type. Sandblasted finish. 1055 Medium carbon steel. Mirror polished head.



WYA071-032 Double Spoon

Black baked paint finish. 1055 Medium carbon steel. Carbon steel head.



WYA555-002 Pry Bar Set

4 Piece set. Roll head. 6, 12, 16 and 20" Length.



WYA490-078 6 Piece Sanding Pad Set



WYA071-008 Autobody Repair Set

7 Piece.



WYA072-021 Slide Hammer Set

10 Piece.



WYA043-016 Upholstery & Trim Tool Set

5 Piece.



WYA046-186 Heavy Duty Pry Bar Set

4 Piece.



WYA046-474 7 Piece Dolly Set



WYA046-642 Painless Dent Removal Set

8 Piece.



WYA104-189 Mini Hook & Pick Set

4 Piece.



WYA094-036 500 Piece Aluminium Rivet Set

9 Sizes.



HAND TOOLS

WYA014-102
Door Lock Hole Reforming Tool with T Handle
 Suitable for flush fitting and recessed lock holes.



WYA014-22
5Lb Knocker Set



WYA125-002
File Holder
 Aluminium.



WYA129-001
Gear Wrench Set
 7 Piece.
 8, 10, 12, 13, 14, 17, 19mm.



WYA173-088
Insulated Terminal Set
 360 Piece.



WYA1T-488A
Plastic Rivet Tool Set
 20 Piece.



WYA2H-192
Cable Tie Set
 375 Piece. Includes 5" wire cutter.



WYA037-082
HSS Spot Weld 45mm Drill Set
 6x8x45mm, 8x8x45mm,
 10x8x45mm.
 In wooden case.



WYA-C0175-006
Carbide Burrs Set
 5 Piece. In wooden case.



WYA315-003
Auto Darkening Welding Helmet



WYA-C0008-016
Crimped Wiggle Wire Set
 50 Piece.



WYA-C0301-004-C
Welding Blanket
 2 x 1.8m



WYA-C0315-003
Quarter Panel Puller



WYAKC-24
Knot Wire Cup Brushes



JMK303
J & M Door Boot / Bonnet Stay Set
 2 Piece



SUL2042MK
Quick Change Hand Rivet Nut Tool Kit
 With 4 Threaded Mandrels, 4 Sizes of Rivet Nuts
 (M3x0.5, M4x0.7, M5x0.8, M6x1.0).



WYA538-010A
Dent Tool Kit



MWMDPS
MWM Parking Sensor Drill Kit
 Make the perfect clean hole, damage free every time, even after painting. Includes 17/18/19/20/21/22mm plus 8.5mm HSS Helical Drilling Tip for pilot holes.



BODY REPAIR EQUIPMENT

OMART610 OMCN Pull Belt Kit 610

High resistance polyester belts suitable for a range of pulling operations, including car body repairs. Double band strengthening seams. Terminal holes with internal stiffening. Protective sheath. Band height 65mm.



Belt lengths:
A: 800mm
B: 1200mm
C: 1800mm
D: 1000mm
E: Sheath for D

OMART355 / OMART356 / OMART353 / OMART354 OMCN Porter Power Kits

Kit includes extension pipes, quick coupling accessories with thread on cylinder, with check valve and metal box.

Per Unit

OMART355	6 Ton Kit
OMART356	6 Ton Kit with Hydraulic Spread
OMART353	12 Ton Kit
OMART354	12 Ton Kit with Hydraulic Spread



OMART356



OMART354

OMART256 OMCN Hydraulic Jack - 1.6 Ton Capacity

Exceptionally solid and easy to handle. Fitted with an automatic overloading valve and hand descent control.

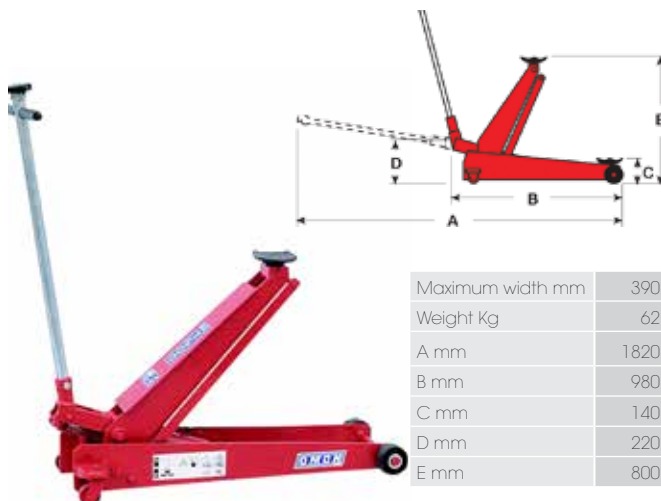

OMART1120E / OMART1120F OMCN Hydraulic Jacks - 2.0 Ton Capacity

Fitted with double pivoting rollers suitable for moving vehicles across floors with grates. Polyurethane wheels.

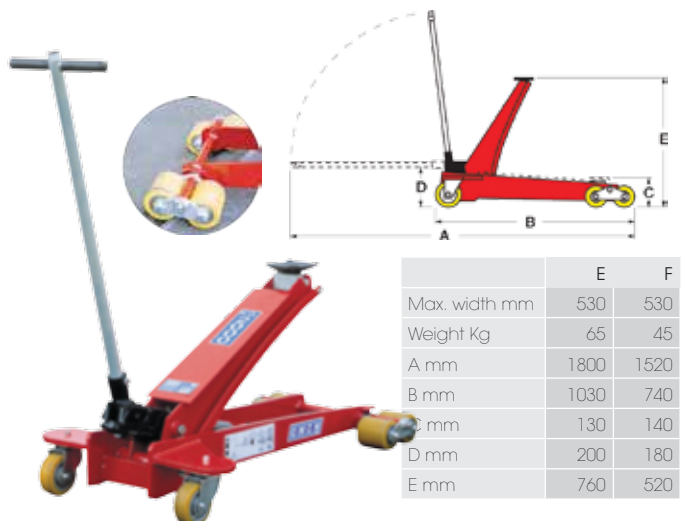

MWMSSTK

MWM Steel Spot / Dent Puller System

The most cost effective, compact and easy to use dent pulling system on the market. Made in Italy. Single phase 230 volt digital steel spot and key welding system for dent repair on steel panels. Comes complete with 800mm pulling bridge, slide hammer kit, squeeze type dent lifter, shrinking tip, wiggle wire and mobile workstation cart. (Stand pictured sold separately.)



MWMPWK

MWM Single Gas Plastic Welder with Built-in Nitrogen Generator

No need to get or refill a Nitrogen bottle again. Converts compressed air into Nitrogen. The latest technology from Italy.

For perfectly clean, extra strong plastic repairs without the fumes. Simply plug it into your power supply and your shop compressed airline and it's ready to weld in about 3-5 minutes with nitrogen gas. Includes a mobile trolley / cart, plastic cleaning knife, smoothing roller, built in hot stapler, staples and a sample pack of welding rods.

Includes:

- Mobile trolley / cart
- Plastic cleaning knife
- Smoothing roller
- Built in hot stapler
- 100 Pre-cut Squiggle staples 0.7mm
- 100 Pre-cut Inside Corner Swiggle staples 0.7mm
- 100 Pre-cut Winding Staples 0.7mm
- Sample pack of PP welding rods.

OMCN Chains & Hooks



OMART303
OMCN 3M Chain with Hook



OMART318
OMCN Twin Hook



OMART323
OMCN Chain Joiner & Shortener



OMART316
OMCN Hook with Fork Coupling



OMART317
OMCN Claw Hook with Fork Coupling



OMART325A
OMCN 2M Safety Cable

OMCN Clamps

OMART251
OMCN Fast Automatic Clamp



OMART276
OMCN Self-locking Scissor Clamp

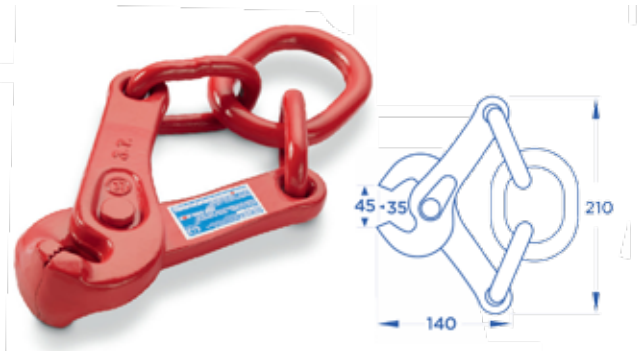

OMART277
OMCN Self-locking Swivel Clamp



OMART299M
OMCN Pincer Clamp

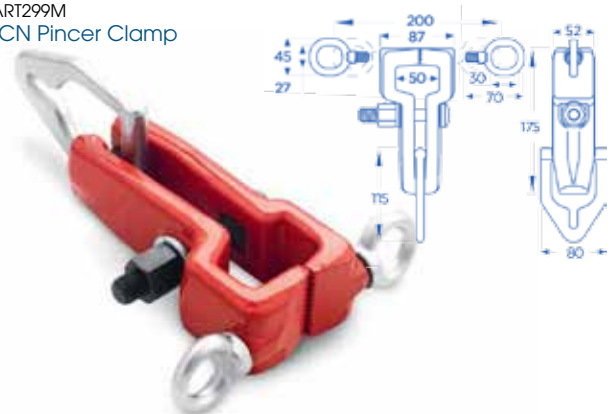

OMART278
OMCN Multi-drilled Pull Plate

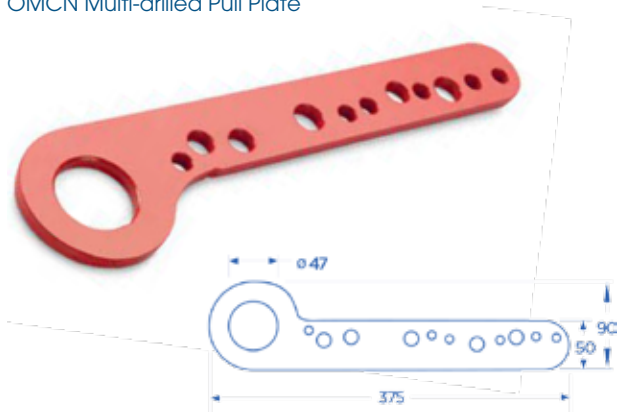

OMART279
OMCN Self-Locking Clamp 100mm Width



OMART280
OMCN Self-Locking Clamp 70mm Width



OMART281
OMCN Self-Locking Clamp 45mm Width



OMART282
OMCN Self-Locking Right Angle Clamp



OMART283
OMCN Pull Yoke for Self-Locking Clamps



OMART285
OMCN Hook Arm with Adjustable Couplings



OMART292
OMCN Adjustable Door Clamp

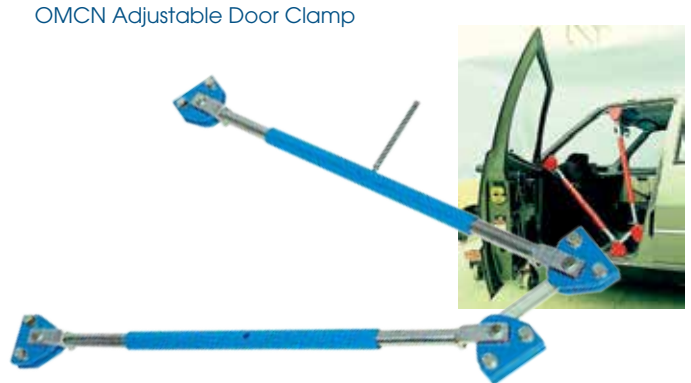



**OMART5521
OMCN 3 Ton Electro-hydraulic Twin-Scissor Lift**

Top quality components. Made in Italy. CE approved with electromagnetic compatibility. Recommended and used by the most prestigious vehicle manufacturers.

3 Ton capacity. Compact floor model. Electro-hydraulic rapid working. Drive ramps convert to standing extension set. (24 Volts) low-tension control. Self-lubricating bushes. Particularly suitable for tyre-shops, car-body-shops and garages.



**YAYS30
Yashima 'Stud-Matic' Electric Dent Pulling Machine**

For single sided welding of maximum 0.3mm (27 ga.) stainless steel. Also performs Heat Shrinking, Dent Pulling, Hole Filling, Nut & Bolt Welding, and Restoring High Spots. Complete with an electrode-tipped slide hammer for quick dent removal, tips for washer welding and shrinkage, a carbon rod and a portable trolley for easy mobility.

YAYS30	
Input voltage	AC200-240V 50/60Hz
Max power	16kVA
Fuse -delayed action	30A no-fuse breaker
Control system	Thyristor control
Ratio of use	4%
Single side welding	Stainless steel plate 0.3mm thickness
Stud welding	Washer, pin & heat shrinkage jobs
Configuration	
Dimensions (HxWxD) :	194x185x260mm
Weight approx.	20 Kg
Cable length	6m



WELDING EQUIPMENT

DEC420S Deca D-Mig 420S 200 Amp Single Phase Mig Welder

Manual wire feed welding (2 steps). Overload protection. ON/OFF switch to turn off the machine without changing the power adjustment. Wheeled welder. Equipped with Euro connection torch.

DEC420S	
volt 50/60 Hz	1 Ph x 230
Fuse Amp	20
Installation Power Kw	2.5 @ 60%
Open circuit voltage V	33
Welding current range	35 - 200
Duty Cycle 15%	180A @ 15%
Duty Cycle 60%	100A @ 60%
Duty Cycle 100%	80A @ 100%
Welding positions N°	6
Wire Suitable Spool mm	200 - 300
Steel wire mm	0,6 - 1,0
Stainless steel wire mm	0,8
Aluminium wire mm	0,8 - 1,0
Configuration	
Dimensions mm	410x710x540
Weight approx.	39 Kg
Protection class	IP 21
Insulation class	H

DEC520SD Deca D-Mig 520SD 180 Amp Single Phase Mig Welder

MIG MAG wire feed welder featuring:

- Self adjusting Wire Speed System
- Equipped with SIMPLE WELD digital synergic technology
- For mild steel solid wire or mig braze-wire Cu Si3 / Cu Al (to weld HSS, EHS, UHS and BORO STEEL), aluminium Mg / Si.
- ON/OFF switch to turn off the machine without changing the power adjustment
- Overload protection

DEC520SD	
volt 50/60 Hz	1 Ph x 230
Fuse (Amp):	16
Installation Power Kw	2 @ 60%
Open circuit voltage V	34
Welding current range	40 - 180
Duty Cycle 20%	150A @ 20%
Duty Cycle 60%	90A @ 60%
Duty Cycle 100%	75A @ 100%
Welding positions N°	6
Wire Suitable Spool mm	200 - 300
Steel wire mm	0,6 - 1,0
Stainless steel wire mm	0,6 - 1,0
Aluminium wire mm	0,8 - 1,0
CuSi - CuAl wire mm	0,8 - 1,0
Configuration	
Dimensions mm	505x840x765
Weight approx.	47.5 Kg
Protection class	IP 21
Insulation class	H



The Synergic MIG control facilitates the welding machine operator's work as it manages wire speed, soft start and burn back in a synergic way with the rest of the machine settings. The welding machine operator must simply activate one of the pre-set programs. The Synergic MIG control is active with all the torches provided for the welding machine.



HAVING CAR-O-LINER EQUIPMENT IS MUCH EASIER THAN YOU THINK...

Are you considering becoming a certified collision repair centre? Don't make the mistake of buying equipment that is not approved by an OEM certified collision repair program. Choose Car-O-Liner.

Why would you accept a lower quality product when you can have the best? Invest in long term success with the innovative technology and tools you need, and see an immediate return on your investment!

Call Paul or Gavin today for more information, Phone (09) 525 1000. Finance is available on any new Car-O-Liner equipment purchased.

Car-O-Liner has been trusted for years by automotive manufacturers around the world to repair their vehicles back to original specifications after an accident. The right equipment is a must in order to repair the car and keep it as safe as it was before it was damaged. The repair needs of the bodyshop are continuously changing, that's why Car-O-Liner offers a wide variety of flexible solutions for repairs that range from minor to structural.



CTR9 Arriving soon



Features & Benefits:

- **Compact and Portable** - technicians move easily around the workshop
- **Power Factor Correction** - allows welding with a long mains cable or a generator as power source.
- **Easy to use** - Enter wire/gas combination and the synergic welding program calculates the rest
- **Versatile** - Handles MIG and TIG (most) welding jobs
- **Fast** - with accessories that speed up the welding process - MMA Electrode holder, TIG Torch and much more
- **Complete** - room for 5kg wire spools, welding and brazing
- **Easy to update** program with SD Card



Welding and Heating Solutions

**CACMI161
Car-O-Liner CMI161 Mig/Mag Welder**

The CMI161 is designed as a compact and portable multi-functional welding machine, primarily for MIG welding but also for the MMA welding process; a modern single-phase 230V inverter machine suitable for workshop use and site welding operations. Anytime, anywhere.

The machine is single-phase (230 V) and has PFC - Power Factor Correction - to allow you to weld with a long mains cable or a generator as your power source.



**MIG with built-in intelligence
Just switch on, press and weld!...**

Select MIG directly on the digital control panel. Enter the wire/gas combination ... CMI161 sets all other parameters.

MMA welding and simple TIG

With an MMA electrode holder (optional accessory), CMI161 uses standard electrodes of up to 3.2 mm. The Hotstart and Arc Force help functions are built in. With a TIG torch (optional accessory), the welding machine also handles the most standard TIG welding jobs - with simple scratch ignition.

MIG-A Twist® the new firing generation

The swan neck rotates 360° for ultimate functionality and comfort. MIG-A Twist, with or without adjustment from the welding handle (optional), is the ultimate match to the Automotive machine's function panel. Ignite - push - weld!

Technical Specifications:

	CMI161
Input voltage + / - 15%	230V , 50-60Hz 1-ph
Fuse	16A
Current Range	20-160A
Open Circuit Voltage	90V
Duty Cycle 100% at 60oC	145A
Duty Cycle 100% at 40oC	165A
Voltage Steps	Stepless, synergic
Wire Dimensions	0.6 - 0.8 mm
Wire Reel Dimensions	5 kg
Wire Reel Speed	Synergic
Protection class	IP223
Weight	13 kg
Dimensions LxWxH, cm	45 x 23 x 37

**CACMI273 / CACMI273 TWIN PULSE
Car-O-Liner CMI273 Twin Mig/Mag Welders**

Compact, fully digitised welding machine with synergic, preset welding programs and automated functions.

Robust for Advanced Welding

With auto-pulse technology for advanced pulse welding of aluminium and pulse brazing of high-tensile steel. Designed for all materials and individual welding applications, including high strength steel. The exceptional 4-wheel wire feed system provides a smooth, reliable wire feed even on softer wires such as aluminium or MIG brazing.

Digital Synergic Control Panels

Switch On - Press - and Weld!

Twin Torch Versatility

With two torches, the CMI273 Twin offers easy switch-over between welding and brazing operations without having to change hoses, wires, wire drive rolls or gas.

Choose Your Power

The welder is capable of operating on single or three phase power.

Extend your reach with the MIG-A Twist® welding torch

Comes with the MIG-A Twist torch. The unique, rotatable swan neck of the MIG-A Twist allows access to hard-to-reach places. It is possible to mount different modules on top of the torch for adjustment of the most important welding parameters.

CMI273 TWIN PULSE Version:

Auto-Pulse Technology gives optimal strength in every weld in aluminium and high tensile steel. The 'Pulse Boost' offers synergic pre-set welding programs and automated functions.

Technical Specifications:

	CMI273	CMI273 TWIN PULSE
Input voltage + / - 15%	1 or 3 x 230V	1 or 3 x 230V
Fuse	10 A	10 A
Duty cycle 100% at 40°C	175/22.8	175/22.8
Duty cycle 60% at 40°C	195A	204/24.3
Duty cycle 100% at 20°C	230A	230
Duty cycle 60% at 20°C	245	245
Current Range A	10-270	15-270
Dimensions (HxWxD)mm:	550x250x640	960x570x870
Weight approx.	26 Kg	55 Kg
Protection class	IP 21	IP 21



Features & Benefits:

- Protects heat-sensitive metals with Auto-Pulse technology (Pulse version)
- Saves time with synergic pre-set welding programs
- Conveniently adjust the weld setting right from the torch
- Reliably feeds soft wires like aluminium with a precise 4-wheel wire feed system
- Comfortably accesses hard-to-reach places with adjustable MIG-A twist torch
- Efficiently switch between key materials with the Tin Wire Feed System on CMI273 Twin - just a click away
- User friendly, flexible and mobile due to compact design & low weight
- Energy saving standby function (15-30W idling) gives less CO2 emission and long component life





CACTR7

Car-O-Liner CTR7 Resistance Spot Welder

12000 Amp Inverter Spot Welder - Unique, new generation welder gives perfect results each time - every time.

The CTR7 has a water cooled high pressure C-Yoke. The Inverter Spot Welder is designed for quality-minded body shops to provide quality spot welds with all new high strength steels using cutting edge inverter technology. A wide range of accessories and sophisticated software with semi-automatic control features guarantees perfect welding results.

Reduce cycle times with new technology

The sharp, easy to read 7" colour screen makes it easy to navigate and set your parameters thereby reducing cycle times and increasing your productivity.

CTR7 also contains the latest technological platform that, in the future, will support internet technology and wireless communication.



Auto 1 mode



Auto 2 mode

Features and Benefits:

- Innovative design with low centre of gravity for increased safety and easy handling.
- Transformer gun technology - greater working range
- Flexible, aluminium, telescopic support arm with integrated balancer (optional)
- Powerful - with welding currents up to maximum of 12,000 Amps
- Sharp, easy to navigate, 7" colour screen
- Water-cooled - with a large 20 Litre tank
- Weldlogger - Documentation and registration of welding data via PC and USB (optional)



Weldlogger

- PC and machine software for documentation and registration of welding data
- Records welding current, time, date, program and result
- Creates work orders
- Saves welding data with print out possibilities via USB

CTR7 Includes the following Yokes:



C-Tong 80mm throat depth, water-cooled

C-Gun 40 mm throat depth, air-cooled



Telescopic Support Arm

An aluminum, telescopic support arm for adjustable height.

Colour Display

The sharp, easy-to-read, 7" color screen makes it easy to navigate and set your parameters thereby reducing cycle times and increasing your productivity.

Transformer Gun

The CTR® 7 C-Tong has a built-in pneumatic feature that presses the welding tips together automatically when triggered.

Better Accessibility

With the 6m cable you can reach more parts/ sections of the vehicle without moving the machine.

Technical Specifications:

CTR7 Spot Welder	
Max voltage	3 x 400V 50Hz
Max power	75kVA
Fuse (delayed action)	16-32 A
Protection class	IP 21
Insulation class	F
Compressed air supply	8 bar (116 PSI)
Power Unit for Transformer Gun (10 kHz)	
Output current	0-200A
Output voltage	560V
Cooling	
Cooling power	1000W
Tank capacity	20L
Flow rate	4.5 L/min
Configuration	
Dimensions (HxWxD) approx:	1130 x 650 x 930mm
Weight approx.	95 Kg
Technical data transformer C- Gun Connection Data	
Primary voltage / frequency:	560V/10 kHz
Primary power (100% duty cycle):	20kVA
Protection class	IP 21
Insulation class	F
Welding Circuit	
Welding amperage:	10,000 A (Current controlled)
Max. output amperage:	12,000 A
No-load voltage:	12.5 VDC
Mechanical Data	
Electrode force	0 - 500daN
Weight approx	11 Kg
Cable length	6m



C-Tong 350mm throat depth, water-cooled



C-Tong 500mm throat depth, water-cooled



CARCH37
Car-O-Liner CH37 Induction Heater

Safe heating without an open flame!

Car-O-Liners induction heating systems offer effective and reliable methods of heating, which result in a cleaner, safer work environment. The advantage of using induction technology is that there is no open flame. The high power CH37 can be used in the same way as a gas torch, but the risk for damaging nearby parts - rubber, plastics and other body parts, when heating with an open flame is completely eliminated. Good regulating controls make it easier to achieve the correct temperature, heating depth and size of the heated area. There are 5 power levels together with a unique regulation and control system to avoid overheating. The Ch37 is a robust 4 kw, ergonomically designed induction heater.

Features & Benefits:

- No preparation required - heats through rubber, plastic, glass, paint
- Safe - **no open flame** making it safer and more economical than gas
- Secure - **Will not damage** nearby heat sensitive parts
- User friendly **front panel with five power control levels**
- Total power control - due to the unique regulation- and control system
- Effective cooling - fan and condensor package in enclosed **water-cooling system**
- High power system quickly heats exactly where the operator chooses

Technical Specifications:

Input voltage	208-240V 50-60Hz single phase 16A
Protection type	IP21
Working frequency	18 - 40 kHz
Main supply power	4kW
Induction power	3.7 kW
Induction cable	3m
Cooling system	Water (decalcified)
Weight	34kg
Water tank	20 L
Cont. Operating Time	20 min. (at 20° C room temp. and max. effect)
Measurements	40 x 35 x 100 cm



CARPNP90
Car-O-Liner PNP90 Universal Riveting Tool

Car-O-Liner's new riveting tool is the perfect solution for completing all common riveting operations in thin sheet metal structures.

Specifically developed for riveting sheet metal in the autobody repair field, the PNP90 is a pneumatic-hydraulic system for riveting and pressing out self-piercing rivets. The equipment's universal technology enables adaption of various attachments for different applications. Easy to use, lightweight and highly efficient - this riveting tool allows your technicians to complete repairs in record time, saving you both time and money.

Kit includes:

- Pressure intensifier PNP90
- Hydraulic gun HP 35 UN
- Rivet clamp NB40

- 106 l x 45 w x 159mm h.
- 1.5Kg weight
- Width, clamp opening: 80mm
- Depth, clamp opening: 40mm

Riveting tool kit UN 2.0

- Setting/closing head 3mm rivet
- Setting/closing head 5mm rivet
- Setting/closing head, flow form rivet
- Punch & calibration mandres/die
- Replacement elastomer rings
- Set of mounting tools
- Spacing adapter
- Locking bolts x 2



Measuring

CARCOT
Car-O-Liner Car-O-Tronic Vision

Struggling with a Measuring System with No Data? Car-O-Tronic Vision is the Answer

Experience Car-O-Tronic Vision – the fastest, most accurate and easiest to use computerized measuring system on the market today! It guides the entire repair process and performs automatic centering, measuring and documentation. Car-O-Tronic Vision is photo based, integrated with Car-O-Data the world’s largest vehicle database and fully compatible with any alignment system.

Powerful and Accurate. Measuring Slide with Remote Control.

The sensor-equipped Measuring Slide with a built-in versatile Remote Control and protective rubber “Bumper-Zones” delivers real-time data three times per second to the advanced and easy-to-use software, it lets the operator manage the entire measuring process without having to be at the computer. Being photo-based and backed by the world’s most comprehensive vehicle database it allows you to accurately and quickly target measuring points.



Easy to Learn and Use

The system is simple to learn and use with automatic centering and measuring abilities, few measurement steps, user-friendly menus and access to the unique Infocenter. Document the entire repair process in pictures with text and e-mail files to insurance companies directly from within the software.

Features & Benefits:

- Over 14,700 Vehicles on database
- Over 90 measuring points (including upper and lower body) with photographs on most vehicles
- No cables or flags for ease of use
- Talks in ‘real-time’, easily keeps track of the repair during pulling process
- Data updated immediately via internet

Car-O-Data, The Worlds Largest Vehicle Database

Covering nearly all new and updated vehicles –presently more than 14,700 models – Car-O-Data consistently provides access to current and reliable data. Being integrated with the software, it truly realizes its enormous potential. New and updated vehicles are continuously measured by our international measuring team in co-operation with automotive manufacturers around the world.

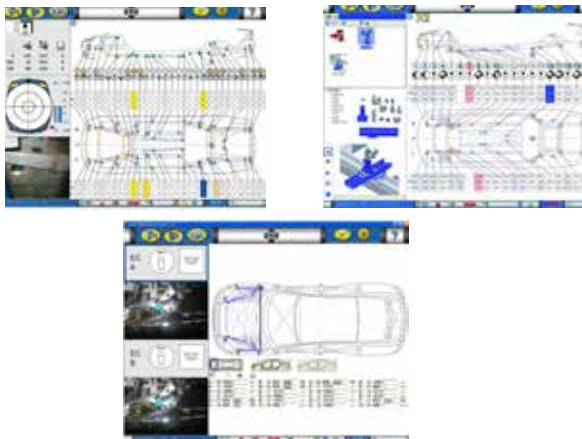

Measuring with Car-O-Tronic Vision is quick and easy:

1. Register the work order and enter car make and model.
2. Conduct measurement, aided by the unique ASP function (Automatic Search Point). Advanced automation allows the system to always select the right point.
3. Print out the results and you are done!

Get All You Need from the Infocenter

The Infocenter, a unique software feature, provides nearly unlimited possibilities for updating vehicle data, news, support and interactive training. It allows you to document the entire repair process in pictures, with text, and email files sent directly to insurance companies from within the software.

Fully Compatible with Any Bench

Adapter Kits make the system fully compatible with almost any alignment bench. Car-O-Tronic Vision is easy to move because of its small size. Analysis and diagnosis of damage can be accomplished even before raising the vehicle on the repair bench. You save time and keep bench systems free.

CAR-O-LINER



CARPOINTX Car-O-Liner Point X Hand-Held Electronic Measuring System



Quick and accurate damage analysis measuring with documentation print-out capability speeds up turn around in any body shop.

PointX™ derives its strength from new generation technology, both in the hand-held measuring arm and software. The lightweight, efficient and easy to use measuring arm, in combination with Car-O-Data, the world's most comprehensive vehicle database, gives you an affordable measuring system that allows you to accurately and quickly target measuring points.

PointX is a measuring device used for diagnostic estimating as well as for gauging detailed and accurate vehicle measurements. With wireless access to the world's most comprehensive vehicle database, you can identify measuring points on more than 14,000 vehicles worldwide.

Extremely lightweight, fast and accurate!

Constructed with a carbon fibre material, the PointX* measuring arm is extremely lightweight making it easy for technicians to manoeuvre around the vehicles to be measured, whether they are on a lift, on an alignment bench or right on the floor.

Vision2 PointX Software

Not only is PointX easy to operate, it is driven with Vision2 Software, a photo-based system that guides the entire repair process. With our comprehensive measuring data, Vision2 and PointX your technicians will be able to provide highest quality diagnosis to your customers.

Features & Benefits:

- Ergonomic design with lightweight carbon fibre construction
- Automatic height calculation speeds up the measuring process
- Upper body P2P measurement capability
- Bluetooth communication with Vision2 PointX Software
- Access to Car-O-Data - measurement data for over 14,000 measured vehicles
- Compatible with Car-O-Tronic electronic measuring system adaptors
- User friendly, one-handed operation through magnetic fixing
- Colour display with simple, intuitive interface
- Electronic documentation with report print out

For all Your Storage Problems:

- Wall Panels
- Storage
- Tool Boards
- Cabinets
- Hooks and Holders
- Tool Wagon



Car-O-Liner Workshop Solutions

Alignment Benches

CARMARK6 Car-O-Liner Mark 6

A flexible system that delivers solid results

Car-O-Liner's Mark 6 is a mobile bench system with the added convenience of drive on mounting. It's designed around the idea that the more flexible a collision repair system is, the more productive it will be.

Using a combination of benches, commercial clamping kits, multiple pulling arms and accessories (all accessories are interchangeable) you can build a system suited to your business. And you can update your Mark 6 system as your needs grow.

Features & Benefits:

- Universal solution for cars, vans, light trucks and SUVs
- Strong lift capacity (max. vehicle weight) of 2,800 kg (6,160 lbs)
- Powerful 10-ton draw aligner pulls from almost any angle, 360° around the vehicle
- Ergonomic approach ramps that can easily be converted into wheel stands allow drive-on mounting for quick set-up, diagnosis and repair.
- Compatible with EVO 1, 2 & 3 Universal Anchoring and Holding Systems
- Precise information with accurate, real-time measuring throughout the process when used with the Car-O-Tronic Vision Measuring System and Car-O-Data, the world's leading vehicle measurement database
- Truck clamping accessories provide strong, no-slip, safe holding
- Interchangeable accessories allow you to build the perfect system for your shop
- Flexible installation — fixed, mobile or pit mountings
- Meets a majority of OEM equipment requirements



Maximum work space between bench and underside of vehicle with longer bench arms



Ergonomic approach ramps that can easily be converted into wheel stands, give excellent working conditions.



Faster loading and unloading

With optional mounting arm that easily clicks in and out



Powerful 10-ton Draw Aligner - The 10-Ton Draw-Aligner pulls from almost any angle, 360° around the vehicle.



In-ground Installation - Leaves frame level with floor allowing for easy drive-over and clean shop appearance.





CARSPEED
Car-O-Liner Speed

Speed - For light structural or cosmetic damage

Today, more than 80% of accidents occur at such low speeds that they do not cause any structural damage to the vehicles involved. Body shops can benefit considerably by focusing their resources on repairing this kind of cosmetic damage quickly and cost effectively.

Speed is designed to reduce set up time so you can realign cosmetic sheet metal damage as well free up your conventional alignment bench, improving workshop efficiency.

Operations such as disassembly, alignment, welding, sanding and filing are easy because there are no ramps or posts to restrict access to the vehicle. With the side pull adapter it is also possible to correct side damage. Speed has a lifting capacity of 2,500 kg and can be used with most vehicles on the market.

Speed will pay for itself very fast. The shorter cycle times and better utilization of workshop resources that Speed provides should result in greatly increased profits! And it's not only your workshop that benefits from Speed's efficiency, but also your customers. Your shop gains the capacity to perform light bodywork quicker and easier than on a larger bench or rack. Other collision damages can also be quickly repaired with perfect accessibility in the same setup.

Features & Benefits:

- Small footprint - makes it the perfect addition to any type of repair/ service shop
- Quick set-up time — drive/roll the car over the lifting platform (4" resting clearance) - increases your workshop capacity
- Versatile - the entire job can be completed using just one bench, shortening cycle times and increasing profits
- Quick set-up time- drive/roll the car over the lifting platform (104 mm resting clearance) - increases your workshop capacity
- "Snap-on" 5-ton draw aligner offers 2 500 kgs of lifting capacity and 360° multi-angle pulling - can handle most types of sheet metal damage and cosmetic damage repair
- Ergonomic design - easy to reach damaged areas with nearly two metres maximum lift height
- Precise information with accurate, real-time measuring throughout the process when used with the Car-O-Tronic Vision Measuring System and Car-O-Data, the world's leading vehicle measurement database
- Can be installed above- or in-ground providing the versatility to complete both cosmetic damage repairs as well as other light service and repair work

Light, but not light weight

Save Time, Make Money!

FAST - Speed is so low that you can drive/roll the car over the lifting platform — no ramps or additional equipment is necessary, saving both time and money





Lifting Arm

Can be moved along a rail on each side of the platform and can also be rotated 180° horizontally

No Ramps Needed Saves Time

The Speed Scissor Lift has such a low profile that you can drive/roll almost any vehicle over the platform eliminating the need for ramps or external accessories.

1.6m Maximum Lifting Height

2500 Kg
Maximum vehicle weight

Versatile - The 5-ton draw aligner can be adjusted in any position and is self-positioning



Ergonomic - Speed can be raised and lowered to the most comfortable working position for each operation. Accessibility is perfect around the entire vehicle.





CARQUICK42
Car-O-Liner Quick 42

The multifaceted bench for both cosmetic and structural damage

Quick 42 is a phenomenal, multi-functional bench designed to manage every type of damage productively and accurately. It provides easy access for cosmetic repairs and offers the ability for anchoring on the same platform if structural repairs are needed, thus shortening repair cycle times and resulting in a 'quick' solution to increase shop profitability.

Speeds up the Repair Process

Fast set-up, easy access, on-wheels measuring, quick anchoring and adjustable working height are features that measurably decrease repair time. Cosmetic repairs can be made while the vehicle is still on its wheels. And if structural damage is discovered, the repairs can begin immediately without changing benches — that's efficiency!

Outstanding Capability to Maximize Output

Compatible with the Car-O-Tronic™ Vision measuring system, the Quick42 offers a complete repair solution, providing technicians a time-saving process to easily diagnose, fixture, and repair automobiles to their pre-accident condition. Maximizing repair capabilities and quality enhances bodyshop output and increases customer satisfaction.

Features & Benefits:

- Drive-on ramps with lifting jacks for quick setup
- Efficient design for all vehicles including 4WD's and vans
- Quick and effective diagnosis of the vehicle whilst still standing on its wheels or in a clamped position
- User friendly hand control with functions for automatic bench tilting, 10 ton pulling and hydraulic jacking
- Built-in multifunctional power unit with central satellite hook-ups for hydraulics and air at both ends of the bench

Quick and efficient diagnosis

of structural damage while the vehicle is supported on its wheels or in a clamped position



Lightweight, multi-purpose ramps

allow quick and easy access to damaged parts, anchoring and upper body areas.



Productivity and Accuracy

10 Ton Draw Aligner
Multi-angle pulling allows easy access to the vehicle

Drive-On Ramps and Sections
Permits a vehicle to be driven onto the bench frame for quick anchoring of chassis clamps

Comfortable Height
Working height of 1.48m

3000Kg
Repair any car, SUV, or light truck

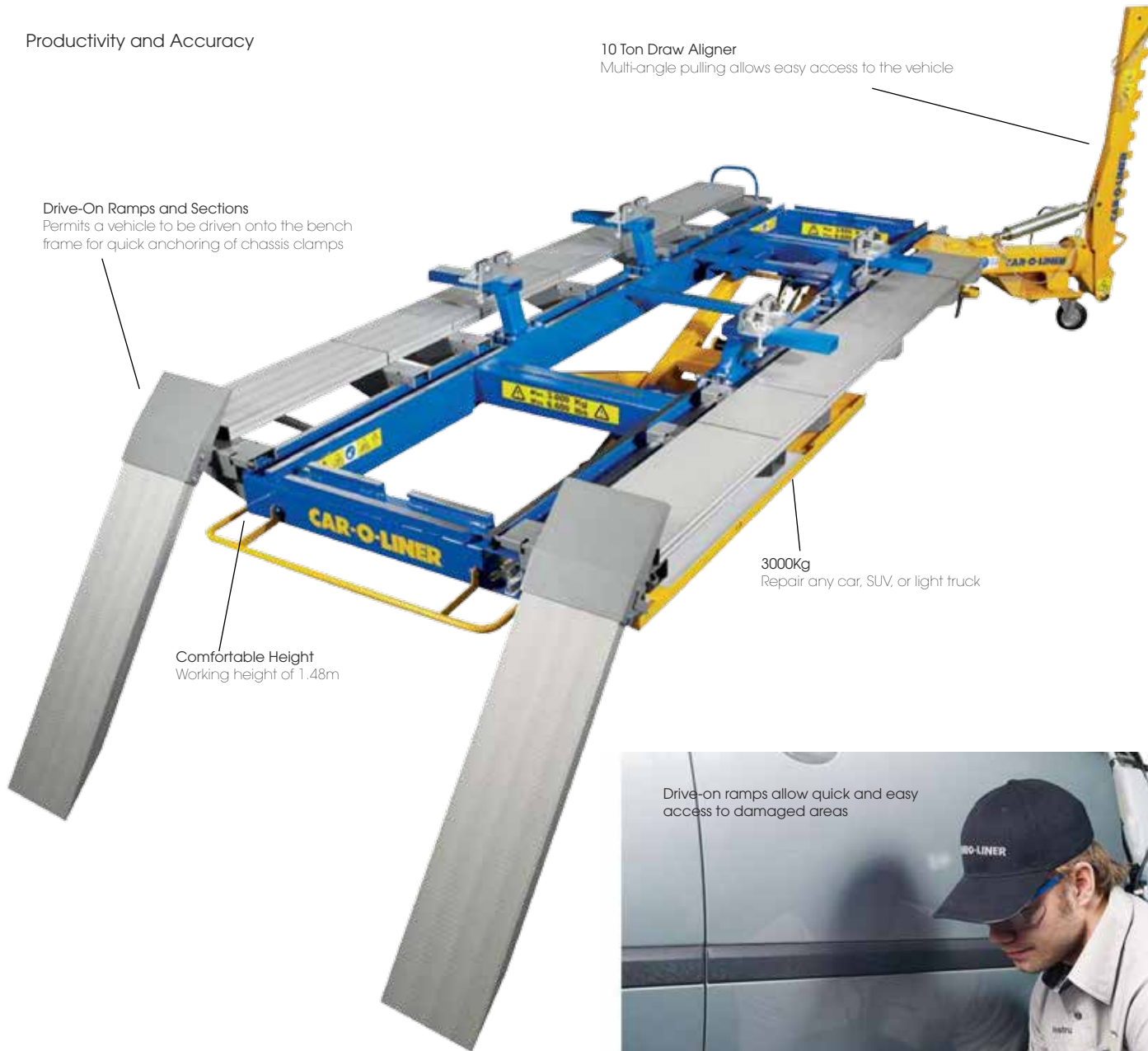

Drive-on ramps allow quick and easy access to damaged areas



Quick hook up of hydraulics





CARBENCHRACK
Car-O-Liner BenchRack

Universal collision repair system

A truly universal and versatile addition to any bodyshop — the BenchRack systems are designed to hold and lift virtually any type of unibody or full frame vehicle. From small cars to light trucks, vans and SUVs.

The unsurpassed BenchRack combines drive-on convenience with a hydraulic lift and removable ramps. Add the tilt feature, which makes loading easier when approach space is limited, and you have a repair bench that can handle everything from slight cosmetic work to full-frame repairs.

Efficiency at its best

With BenchRack, you may lift the vehicle when loaded on the ramps or lift the frame on chassis pads leaving the wheels and wheel wells free. All repair and service operations can be performed quickly and effectively using a single set-up. You avoid the unnecessary interruptions that arise when moving the car between different work stations. This versatility allows for increased productivity for your body shop — saving time and money!

Features & Benefits:

- Universal solution for cars, vans, light trucks and SUVs
- Available in different lengths - there's a BenchRack that's perfect for you
- Powerful 10 ton draw aligner offers 4,200kg pulling force and pulls from almost any angle, 360° around the vehicle
- 4,200kg lifting capacity
- Ergonomic design; removable ramps allow better access to the vehicle
- Precise information with accurate, real-time measuring throughout the process when used with the Car-O-Tronic Vision Measuring System and Car-O-Data, the world's leading vehicle information database
- Truck clamping accessories provide strong, no-slip, safe holding
- Flexible installation; fixed, mobile or pit mountings allows for use in workshop of all shapes and sizes
- Meets a majority of OEM equipment requirements

Available in Lengths up to 6.5m

Drive-on ramps make for quick and easy loading

BenchRamp:

The Universal clamp and bench mounting; strongest for no-slip holding capacity

Removable ramps give full access

BenchRack Truck Clamping



Shop Online 24/7
www.wyatt.co.nz

FAST, FREE NZ WIDE DELIVERY

for all orders over \$250

- RUPES TOOLS
- RUPES BIGFOOT POLISHERS
- RUPES DUST EXTRACTION
 - AIR TOOLS
- CUTTING & SURFACE FINISHING
 - DETAILING SUPPLIES
 - PAINT SUPPLIES
 - REPAIR PRODUCTS
 - EQUIPMENT
- SAFETY EQUIPMENT
- CAR-O-LINER

**Grab a copy of our Latest
Consumables Catalogue**



info@wyatt.co.nz

Your One Stop Equipment & Consumables Supplier

388 Church St, Penrose, Auckland Ph: 09 525 1000



WYATT MACHINE TOOLS